



JOSEPHINE COUNTY, OREGON

DIVISION 4:
DRAINAGE SYSTEM DESIGN STANDARDS
MANUAL
Guidelines for Development

Effective: March 1, 2021

Section 1 – General Design Requirements

- 1.1 The purpose of this manual is to set standards for the design and construction of storm sewer and drainage system improvements to serve new and future development. This manual may be updated periodically and the design engineer shall ensure that they have the latest version.
- 1.2 Storm water, including street, roof, or footing drainage shall not discharge into the sanitary sewer system.

Section 2 – Design Plan Format

- 2.1 Engineering plans and specifications shall be prepared for all public works improvements. Plans shall be clear and legible and show all improvements in sufficient detail to allow for determination of compliance with City standards, and proper field construction. City Engineer or representative may require additional detail if deemed necessary.
- 2.2 Plan shall show the location, stationing, and size of all sewer mains and services including appurtenances such as manholes, clean-outs, tees, and wyes. Stationing shall be called out for specific items to be installed. Matchlines shall be used when continuing to other sheets.
- 2.3 Profile view with stationing and elevation shall be provided for sewer mains. Profile shall show existing ground, finish grade, invert and manhole rim elevations, backfill class materials, pipe size and slope, and all existing and proposed utilities crossing the profile. Profile shall be generated along the sewer pipe centerline. Vertical separation shall be shown for crossing utilities.
- 2.4 Detail drawings shall be provided for typical trench sections, manholes, clean-outs, sewer service laterals, and others as required.
- 2.5 Refer to the City's "Engineering Policy – Guidelines for Development" document for additional requirements and submittal procedures.

Section 3 – Storm Sewer and Drainage System Design Requirements

- 3.1 Storm sewers and related appurtenances shall be provided for new subdivisions, land partitions, and industrial and commercial developments as determined necessary by the City Engineer or representative.
- 3.2 The applicant shall provide stormwater and detention facilities for their development. This includes the stormwater mains, inlets, manholes, laterals for roof and foundation drains, detention systems (if required), control structures (if required), inflow and outflow devices (if required), and energy dissipaters (if required).
- 3.3 All storm sewer and drainage improvements will be designed in accordance with the City of Cave Junction Design Standards Manual and current Storm Water Master Plan and shall meet all City standards.

-
- 3.4 The storm sewer and drainage improvements shall be designed to detain any increased runoff created through the development of the site, as well as convey any existing off-site surface water entering the site from other properties. Facilities shall be sized adequately to convey all necessary flows off site to an approved point of discharge.
 - 3.5 The applicant shall submit hydrology/detention calculations to the City Engineer for review and approval. The applicant shall provide documentation to verify the accuracy of the hydrology and detention calculations.
 - 3.6 The applicant shall show the 100-year overflow (storm) path and shall not design the flow to cross any developed properties.
 - 3.7 Applicant shall account for all surface and stormwater drainage from the point of origin to the ultimate point of discharge to an appropriate receiving stream or storm drainage system. The impact to facilities downstream of the development must be identified to determine if improvements are required outside of the development. If required, applicant will increase the capacity of downstream facilities or, through detention and attenuation, hold drainage on site and release it in a controlled manner so as not to affect the capacity of the downstream facilities.
 - 3.8 The applicant shall design and develop a system that provides for the future extension of the drainage facilities to the entire drainage basin.
 - 3.9 The applicant's engineer shall perform studies and prepare designs based on an engineering analysis which takes into consideration water quality issues, runoff rates, pipe flow capacity, hydraulic grade line, soil characteristics, pipe strength, and potential construction problems.
 - 3.10 Other agencies (i.e. DEQ, ODOT, Josephine County) may require some form of drainage review and impose additional drainage requirements that are separate from and in addition to those of the City. The applicant shall coordinate with these other agencies and resolve any conflicts or concerns in drainage requirements and water quality requirements. The City must receive copies of approval letters, review letters, and other relevant documentation as required.
 - 3.11 Drainage Study
 - 3.11.1 All developments that will increase or modify impervious surface area shall, if further study is not required by the criteria outlined below, submit a drainage study and plan for the development site that provides for system capacity design for a 25 year storm event. The time of concentration for the study shall be determined by using a 10-minute start time and calculated travel times in gutters, pipes and swales for each drainage basin on the development area. The drainage design shall be checked for overflow impacts that may occur in the 25-year storm event and shall include contingency measures to protect both on-site buildings and abutting properties.
 - 3.11.2 A complete drainage study, as outlined below, shall be submitted for all developments that generate public and/or private storm drainage from more than one acre of land or generate peak flows in excess of 0.5 cfs. Developments or redevelopments that create 5,000 square feet of new impervious surface or

modify an existing drainage system with capacity of 0.5 cfs or greater shall also submit a complete drainage study, as outlined below. All developments containing or adjacent to a floodplain, stream, wetland or natural resource area shall review and report their impact to those systems as part of the drainage study required for the development.

3.11.3 If required by the criteria stated above, a complete drainage study shall be provided for a development that is proposed within the City's planning jurisdiction. The study shall include the following:

A. A hydrological study map, which shall include, at a minimum, the following:

1. The entire drainage basin, well defined, and an appropriate amount of area beyond the drainage basin limits; 100-foot minimum distance.
2. Streets important to the Study and the development and street names.
3. Flow arrows in streets and ditches.
4. Contours or spot elevations for verification of direction of overland flow and pipe cover. Contour intervals shall be as follows:

<u>Slope (%)</u>	<u>Contour Interval (ft)</u>
0-10	2
11-25	5
>25	10

5. Drainage areas of all sub-basins (list acres).
 6. Collection points (nodes) at downstream limits of all sub-basins complete with node numbers.
 7. A profile of the storm drain system showing invert elevations, manhole top and bottom elevations, existing utilities, and existing and finished ground line elevations.
 8. Existing and proposed storm drain pipes and channels with sizes and or cross sections included.
 9. Future pipes in the system, complete with proposed sizes, slopes, pipe cover, flow line elevations at manholes, etc.
 10. City drainage master plan information (if available) such as node numbers, basin names (numbers), drainage boundaries, etc.
 11. North arrow, scale, design firm (engineer) name and logo, designer, date, etc.
 12. Environmentally sensitive areas (i.e. gullies, ravines, swales, wetlands, steep slopes, springs, creeks, etc.). For natural drainage features, show direction of flow.
 13. 100-year flood plain with flood elevations and 100-year flood way, as applicable.
- B. Hydrologic calculations to establish runoff volumes (see analysis method requirements and design event in following sections regarding drainage study types)
- C. Hydraulic calculations to establish runoff volumes.

- 3.11.4 Unless specifically required by the City for a particular development, development applications will not be required to provide engineering level details for on-site (out of the right-of-way) pipe profiles or other specific details of the “private” side drainage system. Only information on new components in the right-of-way and connections into existing components must be provided.
- 3.11.5 Drainage Study Types/Categories - The level of detail and scope of work required for a particular drainage study will be governed by the following criteria:
- A. Small Site Study – A small site study shall be required when all of the following criteria are met:
1. Study area less than 5 acres in size.
 2. Study area drains into an established public system with available capacity for the peak flow based on the storm event frequency required as described in the Hydraulic Calculations Section later in these Standards.
 3. The development proposed is a residential development.
 4. Study area does not contain and is not adjacent to a flood plain, stream, wetland or natural resource area.
- B. Mid-Level Development Study – A mid-level drainage study shall be required when the criteria for a Small Site Study cannot be met and when all of the following criteria are met:
1. Study area less than 25 acres in size.
 2. Study area drains to an established public system within the City Limits.
 3. Study area does not contain and is not adjacent to a floodplain, stream, wetland or natural resource area.
- C. Full Drainage Development Study – A full drainage study shall be required when the criteria for a Small Site Study and a Mid-Level Development Study cannot be met. Some examples of when a full study shall be required include, but are not limited to cases where any of the following conditions are met:
1. Study area greater than 25 acres in size.
 2. Developments which require creation of a new outfall and/or exceed existing system capacity.
 3. Study sites which contain or are adjacent to a floodplain, stream, wetland, natural resource area.
 4. Any development which does not qualify for a Small Site or Mid-Level Development Study and which either generates peak flow in excess of 0.5 cfs or greater, or is a redevelopment or development which creates 5,000 square feet or more of new impervious area.
- D. The City Engineer or representative will make the final determination on the level of study required for any specific development.

3.11.6 Hydrologic Calculations – Hydrologic calculations for the various types/categories of drainage studies shall conform to the following minimum guidelines:

A. Small Site

1. Rational peak flow method. When the 'C' factor is 0.5 or greater, the time of concentration and the peak flow from the impervious areas shall be computed separately and compared to the combined area. The higher of the two peak flow rates shall then be used to size the conveyance.
2. Two-year storm event frequency for volumes up to 5 cfs.
3. Five-year storm event frequency for volumes from 5 cfs to 20 cfs.

B. Mid-Level Development

1. Unit Hydrograph Method
2. Storm event as Small Site and using the ten-year event for volumes of 20 cfs to 40 cfs.
3. 25-year storm event for detention facilities where necessary to meet downstream capacity issues.
4. 50-year storm event for volumes above 40 cfs.

D. Full Drainage Development

1. Unit Hydrograph Method.
2. Floodplain analysis if development impacts a floodplain.
3. Storm event as volumes outlined in Small and Mid-Level above and 100-year flood for areas in floodplain.

3.11.7 Hydraulic Calculations

A. In each instance, the method of hydraulic calculations shall be subject to City approval.

B. Site development improvement projects shall address on-site and off-site drainage concerns, both upstream and downstream of a project, including but not limited to:

1. Modifications to the existing on-site storm drainage facilities shall not restrict flows creating backwater onto off-site property to levels greater than the existing situation unless approved by the affected off-site property owners and the City. The affected property owner(s) shall agree to and sign an easement identifying the location of the backwater storage.
2. Storm drainage facilities shall be designed and constructed to accommodate all flows generated from upstream property and the most recent approved land use plan at full development.
3. The design of storm drainage facilities shall analyze the impact of restrictions downstream of the project site. Downstream restrictions that create on-site backwater shall be removed by the developer or the on-site backwater shall be addressed in the design of the development's storm system. The removal of downstream obstructions (i.e. control structures, undersized piping, etc) shall not be allowed if this removal creates downstream capacity problems.

D. Review of Downstream System

1. The design engineer for each development constructing new impervious surface of more than 5,000 square feet shall submit documentation, for review by the City, of the downstream capacity of any existing storm facilities impacted by the proposed development. The design engineer must perform an analysis of the drainage system downstream of the development to a point in the drainage system where the proposed development site constitutes ten percent or less of the total tributary drainage volume, but in no event less than $\frac{1}{4}$ mile.
2. If the capacity of any downstream public storm conveyance system or culvert is surpassed during the Event/CFS (Critical Flow Simulation) level requirements, due directly to the development, the developer shall correct (mitigate) the capacity problem or construct an on-site detention facility unless otherwise approved by the City.
3. If the projected increase in surface water runoff which will leave a proposed development will cause or contribute to damage from flooding to existing buildings or dwellings, the downstream stormwater system shall be enlarged to relieve the identified flooding condition prior to development, or the developer must construct an on-site detention facility.
4. Any increase in downstream flow shall be reviewed for erosion potential, defined as downstream channels, ravines, or slopes with evidence of erosion/incision sufficient to pose a sedimentation hazard to downstream conveyance systems or pose a landslide hazard by undercutting adjacent steep slopes.

3.12 Design of Stormwater Facilities

3.12.1 General

- A. The conveyance system shall be designed to convey and contain at least peak runoff for the Event/CFS design requirements. Structures for proposed pipe systems shall provide a minimum of one foot of freeboard between the hydraulic grade line and the top of the structure or finish grade above pipe for a 25-year peak rate of runoff. Surcharge in pipe systems shall not be allowed if it will cause flooding in portions of a habitable structure, including below-floor crawl spaces.
- B. The design shall be supplemented with an overland conveyance component demonstrating how a 100-year event will be accommodated. This overland component shall not be allowed to flow through or inundate an existing building or dwelling.

3.12.2 Manhole Design

- A. Manholes shall be provided at least every 500 feet, at every grade change, and at every change in alignment and junction of two or more lines. Manhole lids shall have a minimum of six inches clearance from the edge of a curb or gutter and shall not be in a wheel path of the traveled way. Final top

elevation of manhole shall be set flush or not greater than ½" above the finish grade of surrounding area.

- B. All manholes shall be a minimum of 48 inches in diameter.
- C. Pipe crowns of branch or trunk lines entering and exiting junctions shall be at the same elevation. If a lateral is placed so its flow is directed against the main flow through the manhole or catch basin, the lateral invert shall be raised to match the crown of the mainline pipe.
- D. Inside drop and water quality manholes shall be at least 60 inches in diameter with 42 inches of clear space.
- E. All manholes shall have a minimum 12-inch ledge on one side of the channel in the base at an elevation of 0.8 of pipe height, except for water quality manholes.
- F. Details shall be submitted with the plans where pipes into or out of a manhole are larger than 24 inches or where more than four mainline connections are made.
- G. Connections to an existing manhole, elevation of the existing ledge, and elevations of existing inlets and outlets shall be submitted with the plans.
- H. Connections are allowed directly into a manhole providing that they are properly channelized. No more than three side laterals shall be connected to a manhole unless otherwise approved by the City. There shall be a minimum of eight inches separating connections as measured from the outside diameter of the pipe.
- I. A manhole may have a free inside drop of up to two feet. Drops over 24 inches must incorporate an appropriate drop assembly as shown in the included standard detail drawings.
- J. Line manholes may be 'T' top design for pipe diameters 42 inches and larger where no side line connections are present or planned.

3.12.3 Water Quality Components

- A. Water quality structures shall be an approved, manufactured unit. All capacity, efficiency, and operation and maintenance data shall be submitted at the time of plan review.
- B. Each water quality component shall be designed for the runoff from the upstream watershed at build-out, based on the applicable comprehensive land use plan. No flow shall be introduced into the manhole in addition to the design amount.
- C. Water quality manholes shall be a minimum of 60 inches in diameter. Other sized structures may be required depending on the type and extent of treatment desired.

- D. Water quality manholes shall not be used in a submerged or surcharged system. The manufacturer's required head losses shall be accommodated for in the system design.
- E. Water quality components will only be required if determined necessary by the City Engineer or representative or as required by another agency (ODOT, DEQ, etc.)
- F. Water quality components shall be required at last fixture before discharging into stream, lakes or tidal waters.

3.12.4 Piping and Conduit Design

- A. Branch piping in the drainage system shall not be smaller than 10-inches in diameter.
- B. Mainline piping shall be a minimum of 12-inches diameter.
- C. Service laterals for single-family residences (catch basins, etc) shall be a minimum of 6-inches in diameter. All other laterals or branches shall be a minimum of 10-inches diameter. Exception can be made for roof drains which may be 3 or 4 inches in diameter. Drainage sleeves through curbs shall not exceed 3 inches in diameter.
- D. All pipes shall be designed to achieve a minimum velocity of three feet per second (fps) at 0.5 part full based on the following table of 'n' values.

**Table 3.12.4A
Manning's 'n' Values for Pipes**

Material Type	Uniform Flow (Preliminary Design)	Backwater Flow (Capacity Verification)
Concrete pipe and Lined Corrugated PE pipe	.014	.012
Annular Corrugated Metal pipe:		-
2-2/3" x 1/2" plain or fully coated	.028	.024
Paved invert	.021	.018
3" x 1" corrugation	.031	.027
6" x 2" corrugation (field bolted)	.035	.030
Helical 2-2/3" x 1/2" corrugation & corrugated PE pipe	.013	.011
Spiral rib metal pipe and PVC pipe	.013	.011
Ductile Iron pipe (cement lined)	.014	.012
Solid Wall PE pipe (butt fused only)	.009	.009
HDPE Smooth Walled Interior	.012	.010

#Note: Corrugated metal pipe must be pre-approved by City.

- G. All pipes exceeding critical flow velocities shall have analysis data submitted showing the effects of hydraulic jump at manholes and downstream water levels for peak flow situations.

H. Pipe Location

1. All storm drain piping shall be located within the public right of way. Exceptions for systems with physical constraints precluding location within the public right-of-way may be granted at the discretion of the City Engineer or representative.
 - a. Storm pipe located not in a public right-of-way must have a maintained access road acceptance by the City.
2. Storm pipes shall not be located closer than ten feet from the edge of a public street right-of-way, unless otherwise approved by the City Engineer or representative.
3. Easements for storm drainage pipes shall be a minimum of 15 feet in width with wider easements as required for pipes placed at depths greater than 8 feet in depth such that a 1:1 theoretical slope from the pipe centerline would daylight within easement. All storm drainage pipes shall be located at the centerline of easements unless otherwise approved by the City Engineer or representative.
4. Storm pipes shall be located so that manholes are not in the wheel path unless otherwise approved by the City Engineer or representative.
5. Drainage laterals shall be provided on the down slope side of all lots in developments where drainage to the street cannot be provided.

I. Distance between drainage structures

1. The maximum length of pipe between manholes, catch basins, or other drainage structures shall not exceed 500 feet for piping systems utilizing 24-inch diameter pipe and smaller.
2. Large diameter trunk systems shall not exceed 600 feet between structures.

J. Pipe shall be laid on a straight alignment at a uniform grade rate from structure to structure.

K. Pipe Cover

1. Pipe cover shall be measured from the finished ground elevation to the top of the outside surface of the pipe in areas located outside paved areas.
2. In paved areas, the pipe cover shall be measured from the lowest point of the gutter section to the top outside surface of the pipe.
3. Minimum pipe cover shall be 18-inches for reinforced pipe and 36-inches for plain concrete and plastic pipe materials.
4. Engineered solutions and manufacturer supported submittals may be accepted for pipe or specific installations not able to meet these conditions.

L. Perforated or “French drain” systems shall be engineered and submitted to the City Engineer or representative for approval.

3.12.5 Catch Basin/Inlet Design

- A. Trash racks, debris barriers, and/or removable oil and grease traps and 18-inch sumps shall be installed on all inlets to the public storm system.

- B. All inlet and catch basin openings shall be designed to accept flow from a ten-year storm event. Grates shall, as far as practical, be designed to avoid failure due to accumulation of debris.
- C. All catch basins and area drains shall be designed with an 18-inch deep sump as specified by the Uniform Plumbing Code.
- D. A mainline storm pipe shall not pass through a sumped catch basin, unless approved as a manhole /inlet combination.
- E. Flows in streets during the two-year event shall not run deeper than four inches against a curb or extend more than two feet into the travel lane. Streets classed as collector and above and streets in commercial areas shall meet the above requirements for the ten-year event. Inlets in sag location shall be designed with no more than one-foot of depth during the 25-year event.
- F. A catch basin shall be provided just prior to curb returns on streets with a centerline gradient of three percent or more and a street gutter drainage run of 100 feet or more.
- G. Catch basins may connect to main storm lines with a tee connection when the main storm line is at least one size larger than the catch basin line. When the catch basin line is the same size as the main storm line, the connections shall be made at a manhole or other approved structure. The maximum length of pipeline between the catch basin and the mainline shall be 60-feet for 12-inch pipe. Oversize basins (one 30-inch inside dimension) shall be installed when a tee connection is used.
- H. A main storm line shall not pass through a field inlet or ditch inlet.
- I. Ditch inlets shall be located at the upper terminus of a main storm line or shall connect to a main storm line only at a manhole.

3.12.6 Channels and Ditches

- A. Vegetation lined channels are to be used whenever possible.
- B. Rock-lined channels shall be used where a vegetative lining cannot provide adequate protection from erosive velocities.
- C. Constructed open channels shall be sized to pass the required flows and have side slopes no steeper than 3:1. Any proposed constructed channel improvement that does not meet these requirements may be required to be piped, as determined by the City Engineer or representative.
- D. Channels designed to handle the runoff from a development shall be constructed from the development to an existing public drainage conveyance system with an established outfall to a receiving water body.

- E. Channels shall not contain protruding pipes, culverts, or other structures that reduce or hinder the flow characteristics of the channel, except for structures which are required and designed to dissipate velocities. Channels shall be designed to prevent scouring and erosion.
- F. Channel protection shall be as in the following table:

**Table 3.12.6A
Channel Protection for Channel Construction**

Velocity Greater than (FPS)	Velocity Less than or equal to (FPS)	Required Protection	Thickne ss (ft)	Min. Height Above Design Water Surface (ft)
0	5	Vegetative Lining	N/A	0.5
5	8	Rip Rap Class 50	1	1
8	12	Rip Rap Class 100	2	2
12	20	Gabion or Velocity Dissipaters	Varies	2

- G. Access roads or other suitable access ways for maintenance purposes shall be provided when channels do not abut public right-of-way. Access shall be provided along one side of channel, as necessary for vehicular maintenance access.
- H. Access roads shall have a maximum grade of 15 percent and a maximum cross slope of 3 percent.
- I. A 40-foot minimum outside turning radius shall be provided on the access road.
- L. Access roads shall be a minimum of 15 feet wide on curved sections and 12 feet wide on straight sections.
- M. Access roads less than 400 feet in length shall have a turn-around unless approved by the City Engineer or representative.
- N. Access roads shall be designed and constructed to support a 20-ton vehicle under all weather conditions.
- O. The roads shall be constructed of gravel, crushed rock, or asphalt.
- P. Roadside ditches shall be constructed with a maximum depth of two feet as measured from the shoulder of the road.
- Q. Side slopes shall be 3:1 or less.
- R. Ditch velocities, when flowing full, shall not exceed the erosive velocity limits of the soil or the lining in the ditch.

3.12.7 Storm Drain Outfalls

- A. All outfalls shall conform to the requirements of all federal, state, and local regulations.
- B. Outfalls shall be above the mean low water level except as approved by the City Engineer. Installation of tide gates may be required when the outfall is in a tailwater condition.
- C. Erosion must be prevented at the outfall. All outfalls shall be provided with a rock splash or other approved erosion control protection measure. Mechanisms which reduce velocity prior to discharge from an outfall are encouraged and may be required. Examples are drop manholes, energy dissipaters, and rapid expansion into pipes of much larger size.
- D. Other forms of energy dissipation may include stilling basins, drop pools, hydraulic jump basins, baffled aprons, or bucket aprons, shall be provided for outfalls with velocities at design flow greater than 10 FPS.
- E. If required, tidegates, flapgates, or other outlet gates will be installed on specified outfalls. Gates will meet the requirements of the Oregon Department of Fish and Wildlife (ODFW), National Oceanic and Atmospheric Administration (NOAA), and other agencies as applicable.

3.12.8 On-site Detention Design - General

- A. Mitigation of the impacts of new development on the downstream drainage system can be accomplished through on-site detention systems or by improving the capacity of the downstream conveyance system.
- B. On-site detention facilities shall be constructed when any of the following conditions exist:
 - 1. An identified downstream deficiency along with upstream detention, rather than downstream conveyance system enlargement, is determined to be the more effective solution.
 - 2. There is an identified regional detention site within the boundary of the development.
 - 3. The need for pre-treatment of stormwater discharge dictates that flows be detained for water quality processes.
 - 4. There is a need to mitigate flow impacts on receiving streams.
 - 5. There is a need for additional detention due to an increase in impermeable surface area.
- C. When required, on-site stormwater detention facilities shall be designed to capture run-off so the run-off rates from the site after development do not exceed the predevelopment conditions, based upon a 25-year, 24-hour return storm. Volume and duration of predevelopment conditions will be considered.
- D. When required, due to an identified downstream deficiency, on-site stormwater detention facilities shall be designed so that peak run-off rates

will not exceed predevelopment rates for the specific range of storms that cause the downstream deficiency.

- E. Construction of on-site detention shall not be allowed as an option if such a detention facility would have an adverse effect upon receiving waters in the basin or sub-basin in the event of flooding, or would increase the likelihood or severity of flooding problems downstream of the site.
- F. Impervious Area Calculations
 - 1. For single family and duplex residential subdivisions, stormwater quantity detention facilities shall be used for all impervious areas created by the subdivisions, including all streets, residences on individual lots at a rate of 2,640 square feet of impervious surface area per dwelling unit, and other impervious areas. Such facilities shall be constructed with the subdivisions public improvements.
 - 2. For all development other than single family and duplex, the sizing of stormwater detention facilities shall be based on the impervious area to be created by the development, including structures and all streets and impervious areas. Impervious surfaces shall be determined based upon building permits, construction plans, aerial mapping, or other appropriate methods as deemed reliable by the City Engineer or representative.

3.12.9 Detention Pond Design

- A. Detention ponds and other open impoundment facilities such as landscape areas, open playing fields, and parklands, shall comply with the requirements of ORS 537, in general, and more specifically, ORS 537.4.
- B. Facility Geometrics
 - 1. Interior side slopes up to the maximum water surface shall be no steeper than 3H:1V. If interior slopes need to be mowed, the slope shall be 4H:1V
 - 2. Exterior side slopes shall not be steeper than 2H:1V unless analyzed for stability by a geotechnical engineer.
 - 3. Ponds walls and/or dikes may be retaining walls, provided that the design is prepared and stamped by a registered professional engineer and that a fence is provided along the top of the wall and that at least 25 percent of the pond perimeter will be a vegetated soil slope of not greater than 3H:1V.
 - 4. Pond bottoms shall be level, and shall be located a minimum of 0.5 feet below the inlet and outlet to provide sediment storage.
 - 5. Outlet control systems shall utilize gates, valves, weirs, or other control structures and systems to control the outflow from the pond so that the downstream systems are not overwhelmed. If desired, water must be capable of being held in the pond indefinitely.
- C. Overflow/Emergency Spillway
 - 1. A pond overflow system shall provide controlled discharge of the design storm event for developed contributing area without

overtopping any part of the pond embankment for exceeding the capacity of the emergency spillway.

2. The design shall provide controlled discharge directly into the downstream conveyance system.
3. An emergency overflow spillway (secondary overflow) shall be provided to safely pass the 100-year, 24-hour design storm event over the pond embankment in the event of control structure failure and for storm/runoff events exceeding design.
4. The spillway shall be located to direct overflows safely towards the downstream conveyance system.
5. The emergency overflow shall be stabilized with riprap or other approved means and shall extend to the toe of each face of the berm embankment.

D. Access/Maintenance

1. Pond access easements and roads shall be provided when the ponds do not abut public right-of-way. Access roads shall provide access to the control structure and along one or both sides of pond as necessary for vehicular maintenance and as determined by the City Engineer or representative.
2. Access roads shall have a maximum grade of 15 percent and a maximum cross slope of 3 percent.
3. 40 foot minimum outside turning radius shall be provided on the access road.
4. Access roads shall be a minimum of 15 feet wide on curved sections and 12 feet wide on straight sections.
5. Access roads less than 400 feet in length shall have a turn around unless approved by the City Engineer or representative.
6. Access roads shall be designed and constructed to support a 20-ton vehicle under all weather conditions.
7. The roads shall be constructed of gravel, crushed rock, or asphalt.

E. Slope Stabilization (Detention ponds)

1. Pond berm embankment higher than six-feet shall be designed by a geotechnical engineer.
2. The berm embankment shall have a minimum 15-foot top width, where necessary, for maintenance access; otherwise, top width may vary as recommended by the design engineer, but in no case shall top width be less than four feet.
3. The toe of the exterior slope of the pond berm shall be no closer than five feet from the tract or easement property line.
4. The pond berm embankment shall be constructed on native consolidated (or adequately compacted and stable fill soils analyzed by a geotechnical engineer) free of loose surface soil materials, roots and other organic debris.
5. The pond berm embankments shall be constructed by excavating a 'key' equal to 50 percent of the berm embankment cross-sectional height and width or as designed by a geotechnical engineer.
6. The berm embankment shall be constructed on compacted soil (95 percent minimum dry density per AASHTO T99, placed in 6-inch lifts, with the following characteristics:

- a. A minimum of 30% clay
 - b. A maximum of 60% sand
 - c. A maximum of 60% silt
 - d. With nominal gravel content
 - e. Or as designed by a geotechnical engineer.
7. Anti-seepage collars shall be placed on pipes in berm embankments that impound water greater than four feet in depth at the design water surface.
 8. Exposed earth on the pond bottom and side slopes shall be seeded with seed mixture approved by the City Engineer.

3.12.10 Miscellaneous

- A. Other facilities may be utilized for emergency or alternative detention structures when approved by the City Engineer. Examples include:
 1. Parking lots
 2. Roof structures
 3. Underground piping, vaults, or tanks
 4. Infiltration facilities
 5. Injection wells
 6. Parks, fields, or other recreational areas
 7. etc.
- B. Storm water pump stations shall only be provided when gravity service cannot be practically provided. Prior approval from the City is required.
- C. Any alternative detention facility must meet all the local, state, and federal design requirements and be approved by the City Engineer.

Section 4 – Construction Provisions

- 4.1 All work within the public right-of-way shall be conducted by a licensed and bonded contractor. This requirement shall be stated on the construction drawings.
- 4.2 City shall be notified at least 3 working days in advance prior to commencing construction work.
- 4.3 Traffic control shall be signed, flagged and conducted in a manner conforming to ODOT standards (Manual of Uniform Traffic Control Devices, MUTCD) and approved by the City, where appropriate. If road closures or detours are anticipated, prior approval from the City and ODOT officials must be obtained, as appropriate.
- 4.4 Safety Requirements. The contractor is responsible for observing the safety of the work and all persons and property coming into contact with the work. The contractor shall conduct his work in a manner complying with the requirements prescribed by Occupational Safety and Health Administration (OSHA).
- 4.5 Progress. Construction shall proceed in a systematic manner to minimize public inconvenience and disruption of services. All excavations, embankments, stockpiles, waste areas, etc. shall be kept protected. All roads, ditches, etc. shall be kept free from

debris and shall be continually cleaned during the work. Dust control measures shall be employed as required and directed by the City.

- 4.6 Protection of Existing Improvements. Contractor shall contact the Utility Notification Center (811) at least 48 hours in advance of digging operations to get approximate locations for buried utilities. Exact locations of buried facilities may not be known or shown and contractor is responsible to pot-hole carefully in advance of the work to avoid such facilities. Contractor shall coordinate with all utilities and notify them immediately in the event of any damage. Contractor shall protect, repair, and replace any damaged utilities as directed by the persons responsible for such utility. All landscape, grass, shrubs, signs, pavements, mail boxes, driveways, culverts, gravel surfacing, fencing, etc. shall be protected from damage and returned to conditions as good, or better than existed prior to construction. All costs for protection, repair, and replacement of all existing items shall be borne entirely by the contractor. Contractor shall obtain a release from any property owners for any claims of injury or property damage prior to final acceptance of the work by the City.
- 4.7 All existing survey monuments and control shall be protected, including individual property corner monuments. Any such monuments destroyed or altered during construction shall be restored by the contractor or developer in accordance with Oregon Revised Statutes as applicable.
- 4.8 Any temporary disruption to water or sewer service must be coordinated with, and approved by the City and kept to the minimum length of time necessary. City shall be notified at least 2 working days in advance of when an approved shut-down is desired. Contractor shall not operate any valves or hydrants without the City's approval.
- 4.9 Trench foundation grades shall be constructed to within 0.1 feet of the grade shown in the plans. Surface tolerances shall be within 0.02 feet of plan elevation at any one point.
- 4.10 For pipelines, vertical deviation from true grade shall not exceed 0.02 feet (0.24 inch). Horizontal tolerance for deviation from line shall be 0.03125 feet (3/8 inch). Depressions or bellies which create the potential for solids deposition are not allowed.
- 4.11 Compaction testing equipment (nuclear gauge) shall be furnished and operated by the contractor or an independent testing firm shall be retained by the contractor or developer to perform compaction testing. Testing shall conform to the ODOT Manual of Field Testing Procedures (MFTP). Compaction testing shall be conducted in the presence of the City's inspector, representative or developers engineer. Sufficient tests will be taken to ensure that the materials and compaction efforts being used are adequate to obtain the required density. Several tests shall be taken on each lift placed during the first day of backfill operations. Additional tests will be taken periodically during the work. At minimum, 2 compaction tests shall be taken for each trenchline (manhole to manhole). Alternate materials or methods will be required if adequate compaction is not being obtained. In no case shall pipe laying continue if inadequate compaction results until a resolution is provided.
- 4.12 Construction staking will be provided by the Developer's Engineer for establishing the location of the system. Offset stakes shall be placed at no more than 100 foot intervals along the mainline and at each manhole. Each lateral location shall be staked.

- 4.13 Open trench length at any time shall not exceed 100 feet unless otherwise approved. Related resurfacing shall be completed within 800 feet of the open trench limit.

Section 5 – Storm Sewer and Drainage System Materials

- 5.1 All materials shall be newly manufactured. No rebuilt, reconditioned or used material will be allowed.
- 5.2 Oregon Standard Specifications (OSS) – Means the 2002 Oregon Standard Specifications for Construction produced by ODOT and APWA, including latest revisions.
- 5.3 Concrete shall conform to OSS Section 00440, Commercial Grade Concrete. Compressive field strength shall not be less than 3,000 psi at 28 days. Maximum aggregate size shall be 1½-inches. Slump shall be between 2 and 4 inches.
- 5.4 Non-Shrink Grout. Grout shall be Sika 212, Euco N-S, Five Star, or approved equal nonmetallic cementitious commercial grout exhibiting zero shrinkage per ASTM C827. Grout shall not be amended with cement or sand and shall not be reconditioned with water after initial mixing. Nonshrink grout shall be placed and packed only with the use of an approved commercial bonding agent. Unused grout shall be discarded after 20 minutes.
- 5.5 Manholes
- 5.5.1 Manholes shall conform to ASTM C478-03 with yard permeability tests passing ASTM C497-03 prior to delivery. Manhole steps shall be plastic with ½” grade 60 steel reinforcing bar encapsulated with injection molded copolymer polypropylene with serrated surfaces. Preformed gaskets shall be Ram-Nek, Kent-Seal No. 2, or approved equal.
- 5.5.2 Manhole Frames and Covers. Casting shall be tough, close-grained gray iron, smooth and clean, free from blisters, blowholes and all defects and conforming to ASTM A48, Class 30. All bearing surfaces shall be planed, ground or machined to ensure flat, true surfaces. Watertight frames and covers shall be installed at all locations subject to flooding or ponding. Tamperproof frames and covers required in off-street areas and easements. Cap screws for bolt-down covers shall be stainless steel with 60,000 psi minimum tensile strength conforming to ASTM A453.
- 5.6 Trench Backfill Materials
- 5.6.1 Foundation Stabilization: 3”-0 to 6”-0 aggregate base rock meeting OSS Sections 00641 and 02630. Required when native trench foundation material contains groundwater, or is unsuitable to provide a firm foundation in the opinion of the City Engineer or representative.
- 5.6.2 Pipe Bedding and Zone: ¾”-0 dense-graded aggregate, uniformly graded from coarse to fine and meeting OSS Section 02630.10. Clean sand may be substituted for pipe zone.

-
- 5.6.3 Class A Backfill: Native or common excavated material, free from organic or other deleterious material, free from rock larger than 3-inches, and which meets the characteristics required for the specific surface loading or other criteria of the backfill zone in the opinion of the City Engineer or representative. If stockpiled material becomes saturated or unsuitable, Class B, C or D Backfill shall be substituted.
 - 5.6.4 Class B Backfill: $\frac{3}{4}$ "-0 dense graded aggregate, uniformly graded from coarse to fine and meeting OSS Section 02630.10.
 - 5.6.5 Class C Backfill: Clean sand with no particles larger than $\frac{1}{4}$ -inch.
 - 5.6.6 Class D Backfill: Pit run or bar run material, well graded from coarse to fine, with maximum aggregate size of 3 inches.
 - 5.6.7 Class E Backfill (CLSM): Controlled Low-Strength Material (cement slurry) conforming to OSS Section 00442.
 - 5.6.8 Compaction: Material (except Class E Backfill) shall be compacted in multiple lifts (6-inch maximum lift) to obtain 95% of the maximum dry density as determined by AASHTO T-99.
 - 5.6.9 All Backfill within public right-of-ways or within 5 feet of a traveled surface shall be Class B Backfill, except where Class E Backfill is required under pavements as required by the City or State.
- 5.7 Storm Drain Pipe Materials – Design engineer to determine the most appropriate material for the project. Approval of the City Engineer or representative is required for pipe material choices.
- 5.7.1 PVC gravity pipe, 4- through 15-inch nominal diameter shall be rubber gasketed, SDR35 minimum, conforming to all requirements of ASTM D3034 in accordance with ASTM D1784. Pipe shall integral wall-thickened bells with bonded-in elastomeric gaskets meeting ASTM F477.
 - 5.7.2 PVC gravity pipe, 18- through 27-inch nominal diameter shall be rubber gasketed, SDR35 minimum, conforming to all requirements of ASTM F679 in accordance with ASTM D1784. Pipe shall integral wall-thickened bells with bonded-in elastomeric gaskets meeting ASTM F477.
 - 5.7.3 HDPE gravity pipe shall meet the requirements of AASHTO M-294. Pipe end connections shall be water-tight with rubber or neoprene bell and spigot ends. HDPE shall be corrugated outer walls with smooth and flat inner walls.
 - 5.7.4 Aluminum CMP culverts shall be aluminum spiral ribbed, with 2-2/3" x 1/2" corrugations and conforming to AASHTO M-196. Gauge of pipe shall be per manufacturer recommendations and approved by City Engineer.
 - 5.7.5 Reinforced Concrete Pipe shall conform to ASTM C-76 Class IV. Joints shall be bell and spigot with rubber gaskets.

5.8 Fittings

- 5.8.1 PVC fittings for gravity pipe shall be rubber gasketed sewer fittings meeting ASTM D3034, SDR 35, ASTM F477, and ASTM D3212.
- 5.8.2 Other fittings shall include tees, bends, and plugs and shall be of the same material as the mainline pipe.
- 5.8.3 Manhole Connections
 - 5.8.3.1 Connections to precast manhole sections shall be accurately core-drilled and shall utilize a properly sized flexible rubber boot providing a watertight seal. Adapter shall be factory tested for watertightness up to 10.8 psi. Kor-N-Seal as manufactured by NPC, Inc. or approved equal.
 - 5.8.3.2 Connections to cast-in-place concrete shall be made with a rubber water-stop grout ring. Ring shall clamp to pipe with stainless steel clamp and have water-stop ribs. Water-stop Grouting Ring by Press-Seal Gasket Corp., or approved equal.
- 5.8.4 Connections for aluminum CMP piping shall be made with 12-inch wide dimple bands of the same material and gauge as the run of pipe. Use minimum of 20' long CMP sections, except for end run.

5.9 Catch Basins

- 5.9.1 Precast basins and inlets shall be of Portland cement concrete conforming to AASHTO M199M/M (ASTM C478).
- 5.9.2 Cast-in-place concrete basins and inlets will be allowed. CIP basins will meet the requirements of commercial grade concrete as specified in Section 00440 of the 2002 Oregon Standard Specifications including latest versions of. CIP units shall be equivalent or superior to the specified precast units.
- 5.9.3 Frames, grates, and covers shall meet the requirements of AASHTO M227, Class 65. Casting shall be tough, close-grained gray iron, smooth and clean, free from blisters, blowholes and all defects. All bearing surfaces shall be planed, ground or machined to ensure flat, true surfaces.

Section 6 – Storm Sewer and Drainage System Installation (Workmanship)

- 6.1 Prepare trench in accordance with the standard detail in a safe manner. Place and compact foundation stabilization materials as required. Notify City to allow for inspection of the trench bottom.
- 6.2 Place and compact pipe bedding material before placing pipe in the trench. Dig depression for pipe bells to provide uniform bearing along the entire pipe length. Thoroughly compact bedding material to prevent future bellies.

-
- 6.3 Prior to lowering pipe into the trench, the Engineer or City representative will check for damage to the pipe. The Contractor shall repair or replace, as directed, all damaged or flawed pipe prior to installation.
 - 6.4 Place materials in the pipe zone in layers not greater than 6 inches thick and in a manner that equalizes the pressure on the pipe and minimizes stress. As required under the haunches of pipe and areas not accessible to mechanical tampers or to testing, compact with hand methods to ensure thorough contact between the material and the pipe. Before placing the pipe zone material, condition, aerate, or wet the material so that the moisture content of each layer is within minus 4% to plus 2% of optimum moisture content.
 - 6.5 Provide proper Backfill Class material as required. Backfill the trench above the pipe zone in successive lifts. Do not allow the backfill to free-fall into the trench until at least 3 feet of cover is provided over the top of the pipe. Modify the compaction as necessary to protect the pipe. Compact each lift to not less than 95% of the maximum density.
 - 6.6 If the specified compaction is not obtained, contractor shall remove material, modify compaction procedures, and/or reduce the thickness of lifts as required. Do not proceed with additional excavation or pipe laying until the backfill can be compacted to the satisfaction of the City.
 - 6.7 When CLSM Backfill is required, backfill above pipe zone with CLSM material. If the CLSM is to be used as a temporary surfacing, backfill to top of the trench and strike off to provide a smooth surface. If CLSM is not to be used as a temporary surface, backfill to bottom of the proposed resurfacing. Use steel plates to protect the CLSM from traffic a minimum of 24 hours.

STORM DRAINAGE

STANDARD DETAIL DRAWINGS INDEX

- D-050: STANDARD UTILITY LOCATIONS
- D-100: TYPICAL STORM DRAIN TRENCH DETAIL
- D-105: STREET CUT STANDARD DETAIL
- D-150: PIPE ANCHOR / TRENCH CUT-OFF WALL DETAIL
- D-200: STANDARD MANHOLE
- D-201: POLLUTION CONTROL MANHOLE
- D-205: FLAT-TOP MANHOLE
- D-210: MANHOLE BASE STANDARD DETAILS
- D-220: STANDARD INSIDE DROP MANHOLE W/ DEFLECTION PLATE
- D-250: MANHOLE COVER AND FRAME DETAILS
- D-260: MANHOLE FRAME GRADE ADJUSTMENT
- D-300: STANDARD INLETS, FRAMES & GRATES
- D-301: TRAPPED/POLLUTION CONTROL CATCH BASIN
- D-302: TYPICAL DITCH INLET
- D-303: TYPICAL AREA DRAIN INLET
- D-304: HEADWALL WITH TIDEGATE



City of Cave Junction
222 W. Lister Street
Josephine, Oregon 97523
(541) 592-2156

STANDARD DETAIL DRAWING INDEX

DETAIL NO.

D-010

03/01/2021

SEE DWG. T-050 FOR STANDARD STREET WIDTHS AND SECTIONS



NOTES:

1. WATER LOCATED 3'-6" INSIDE FROM FACE OF CURB OR AS OTHERWISE DIRECTED.
2. 10' HORIZONTAL SEPARATION BETWEEN WATER AND SEWER WHERE POSSIBLE. COMPLY WITH SEPARATION REQUIREMENTS OF OAR 333-061-050.
3. WATER DISTRIBUTION MAINS SHALL HAVE 36" MINIMUM COVER OR AS OTHERWISE DIRECTED.
4. SEWER MAINS SHALL HAVE 5.25' (63") MINIMUM COVER UNLESS OTHERWISE APPROVED TO AVOID CONFLICTS WITH WATER AND OTHER UTILITIES.
5. WATER MAINS SHALL BE LOCATED ON NORTH OR EAST SIDE OF STREET WHEN PRACTICAL.
6. WATER, SEWER, STREET AND DRAINAGE SYSTEMS ARE SUBJECT TO CITY STANDARDS.
7. MANHOLE LIDS SHALL NOT BE LOCATED DIRECTLY IN NORMAL WHEEL PATH.
8. ALL LAYOUTS AND LOCATIONS ARE SUBJECT TO CITY APPROVAL.



City of Cave Junction
 222 W. Lister Street
 Josephine, Oregon 97523
 (541) 592-2156

STANDARD UTILITY LOCATIONS

DETAIL NO.
D-050
03/01/2021

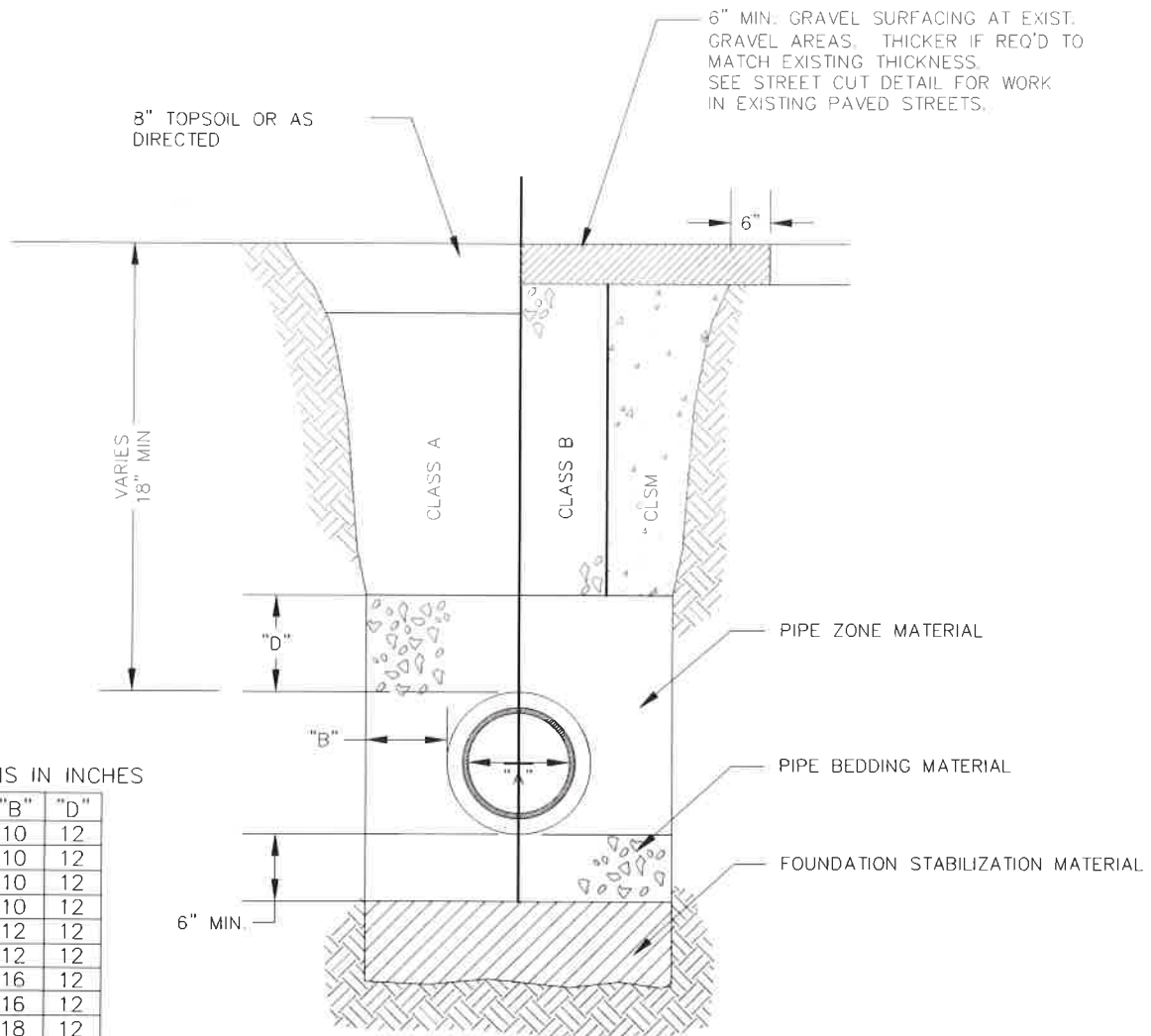

DIMENSIONS IN INCHES

"A"	"B"	"D"
4	10	12
6	10	12
8	10	12
10	10	12
12	12	12
15	12	12
18	16	12
21	16	12
24	18	12
30	18	12
36	24	14

NOTES:

1. TRENCH EXCAVATION SHALL BE CONDUCTED IN A SAFE MANNER WITH ALL NECESSARY BRACING AND SHORING PROVIDED FOR COMPLIANCE WITH OSHA.
2. FOUNDATION STABILIZATION SHALL BE PROVIDED WHEN MATERIAL AT BOTTOM OF TRENCH IS UNSUITABLE IN THE OPINION OF THE CITY TO PROVIDE A STABLE TRENCH BASE.
3. CONSTRUCTION IN PUBLIC RIGHT-OF-WAY SHALL COMPLY WITH CITY STANDARDS.
4. CLASS B BACKFILL REQUIRED IN ALL ROADWAYS AND TRAFFIC PATHS EXCEPT WHERE CLSM BACKFILL IS REQUIRED BY COUNTY, ODOT, OR CITY.
5. MATERIALS SHALL BE IN ACCORDANCE WITH THE CITY STORM DRAINAGE DESIGN STANDARDS MANUAL.
6. COMPACT ALL FILL AS SPECIFIED.



City of Cave Junction
 222 W. Lister Street
 Josephine, Oregon 97523
 (541) 592-2156

**TYPICAL TRENCH DETAIL
 STORM DRAINAGE SYSTEM**

DETAIL NO.
D-100
03/01/2021

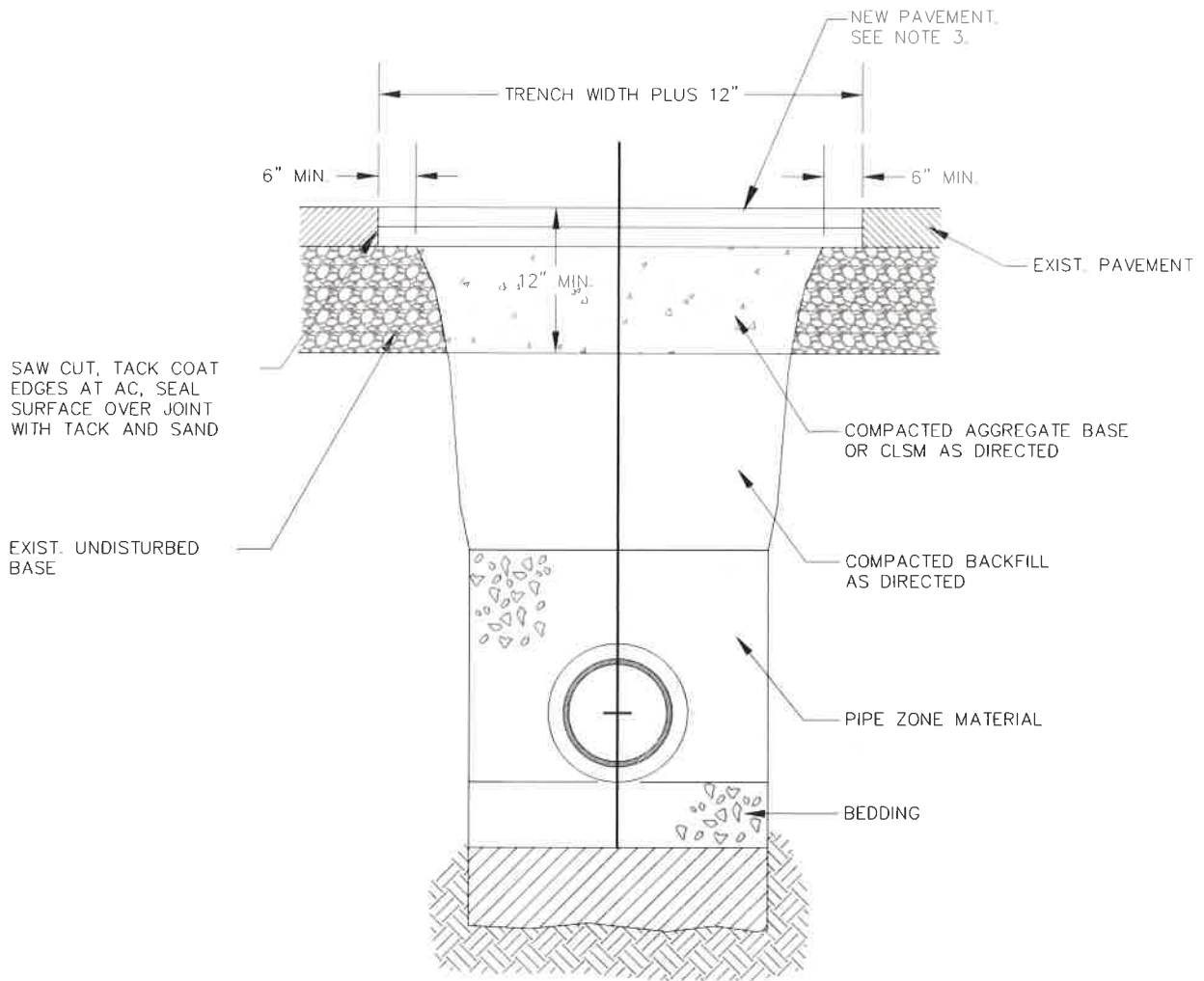

NOTES:

1. ALL EXISTING AC OR PCC PAVEMENT SHALL BE SAWCUT IMMEDIATELY PRIOR TO REPAVING.
2. CONCRETE PAVEMENT SHALL BE REPLACED WITH CONCRETE TO A MINIMUM THICKNESS OF 6 INCHES OR TO THE THICKNESS OF REMOVED PAVEMENT, WHICHEVER IS GREATER.
3. PLACE AC MIX TO A MINIMUM THICKNESS OF 4 INCHES OR THE THICKNESS OF REMOVED PAVEMENT, WHICHEVER IS GREATER. COMPACT AS DIRECTED. AC PAVEMENT SHALL BE PLACED IN AT LEAST TWO 2" LIFTS.
4. COMPLY WITH THE REQUIREMENTS OF THE AGENCY HAVING JURISDICTION OVER THE ROAD IN WHICH THE STREET CUT OCCURS.



City of Cave Junction
 222 W. Lister Street
 Josephine, Oregon 97523
 (541) 592-2156

**STREET CUT
 STANDARD DETAIL**

DETAIL NO.

D-105

03/01/2021

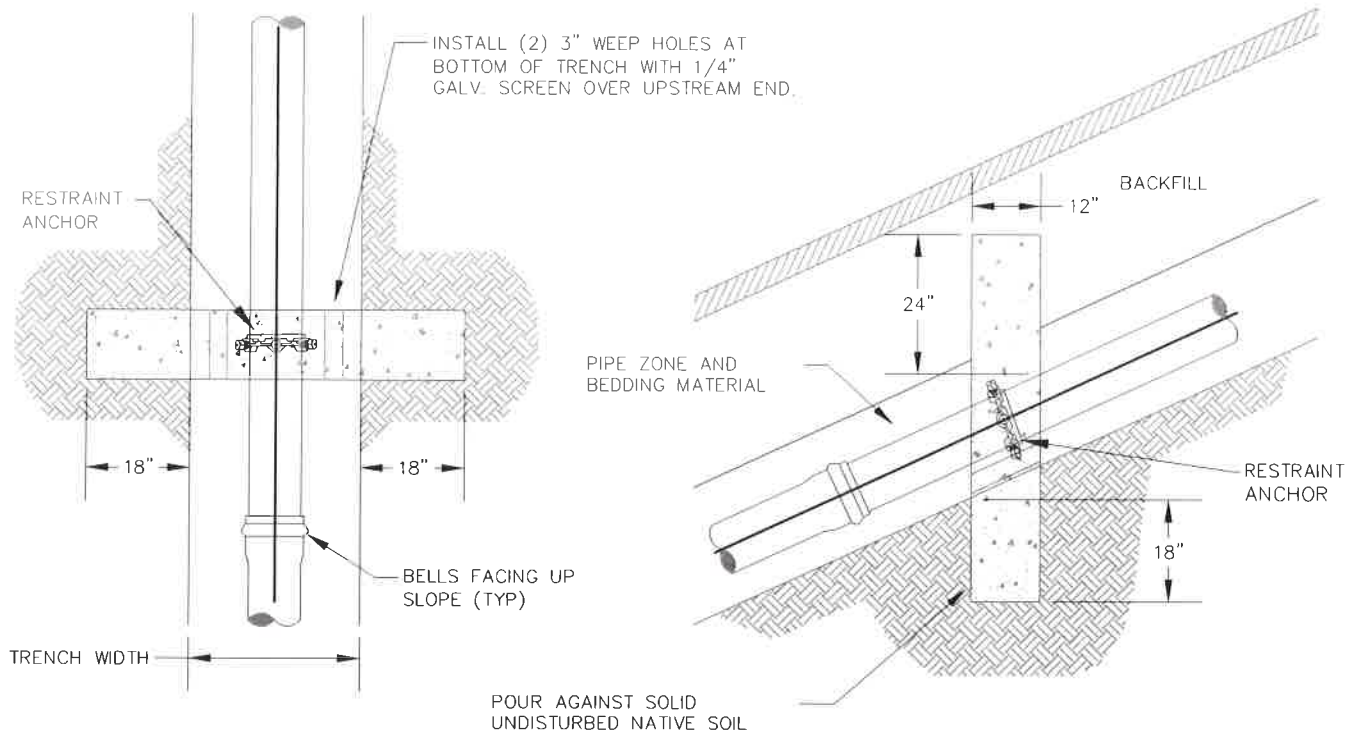

NOTES:

1. CUT-OFF WALLS REQ'D AT ALL PIPELINES WHERE SLOPE EXCEEDS 20%.
2. RESTRAINED JOINT PIPE REQUIRED AT SLOPES BETWEEN 15% AND 20%.
3. WALLS SHALL BE FORMED WITHIN TRENCH. REMOVE FORMS PRIOR TO BACKFILLING.
4. CONCRETE SHALL HAVE 3000 PSI COMPRESSIVE STRENGTH MIN. (CLASS 3000).
5. SPACING OF WALLS SHALL BE:

SLOPE	SPACING
20-34%	35 FEET
35-50%	25 FEET
51-+ %	15 FEET



City of Cave Junction
 222 W. Lister Street
 Jackson, Oregon 97523
 (541) 592-2156

**PIPE ANCHOR / TRENCH
 CUT-OFF WALL DETAIL**

DETAIL NO.
D-150
03/01/2021

CAST IRON (H-20 RATED)
MANHOLE COVER AND FRAME SET
FRAME IN NON-SHRINK GROUT,
SEE STANDARD DETAIL D-250

PRECAST REINFORCED
GRADE RINGS, 3 LAYERS MAX.
2" MIN., 12" MAX.
SET IN NON-SHRINK GROUT.

PRECAST ECCENTRIC CONE
SLOPE FACING DOWN GRADE
36" TALL

KEYED JOINTS WITH PRE-
FORMED SEAL (RAM-NEK)
OR RUBBER RING GASKET
BY MFG. (TYP. ALL JOINTS)
SEAL WATERTIGHT

ALL PRECAST MANHOLE
SECTIONS SHALL MEET
ASTM C-478.

FLAT-TOP MANHOLE
REQUIRED WHEN DEPTH
FROM FINISH GRADE TO
INVERT IS LESS THAN
6 FEET.

INTERIOR DROPS EXCEEDING 24"
REQUIRE DROP MANHOLE.

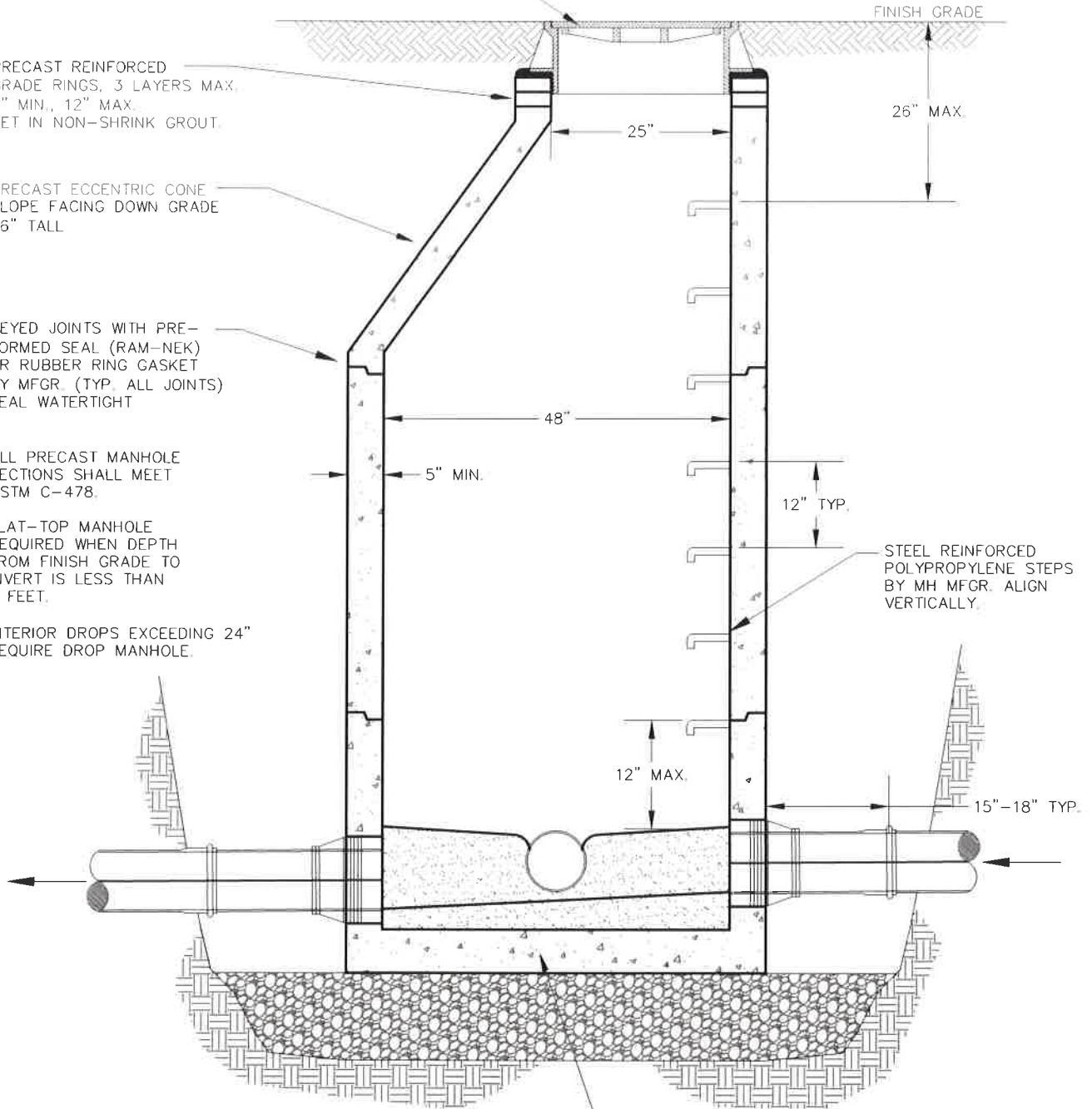

SEE MANHOLE BASE
STANDARD DETAIL D-210

LARGER INLET PIPES
THAN 24" WILL REQUIRE
A SPECIAL DESIGN AND
APPROVAL FROM CITY
ENGINEER



City of Cave Junction
222 W. Lister Street
Jackson, Oregon 97523
(541) 592-2156

**STANDARD MANHOLE
PIPES LESS THAN 24" DIAM.**

DETAIL NO.

D-200

03/01/2021

CAST IRON (H-20 RATED)
MANHOLE COVER AND FRAME, SEE
STANDARD DETAIL D-250

FOR STANDARD MANHOLE DETAILS,
SEE D-200
FOR FLAT TOP MANHOLE DETAILS,
SEE D-205

SAND COLLAR OR
FLEXIBLE CONNECTION
AT INTERFACE

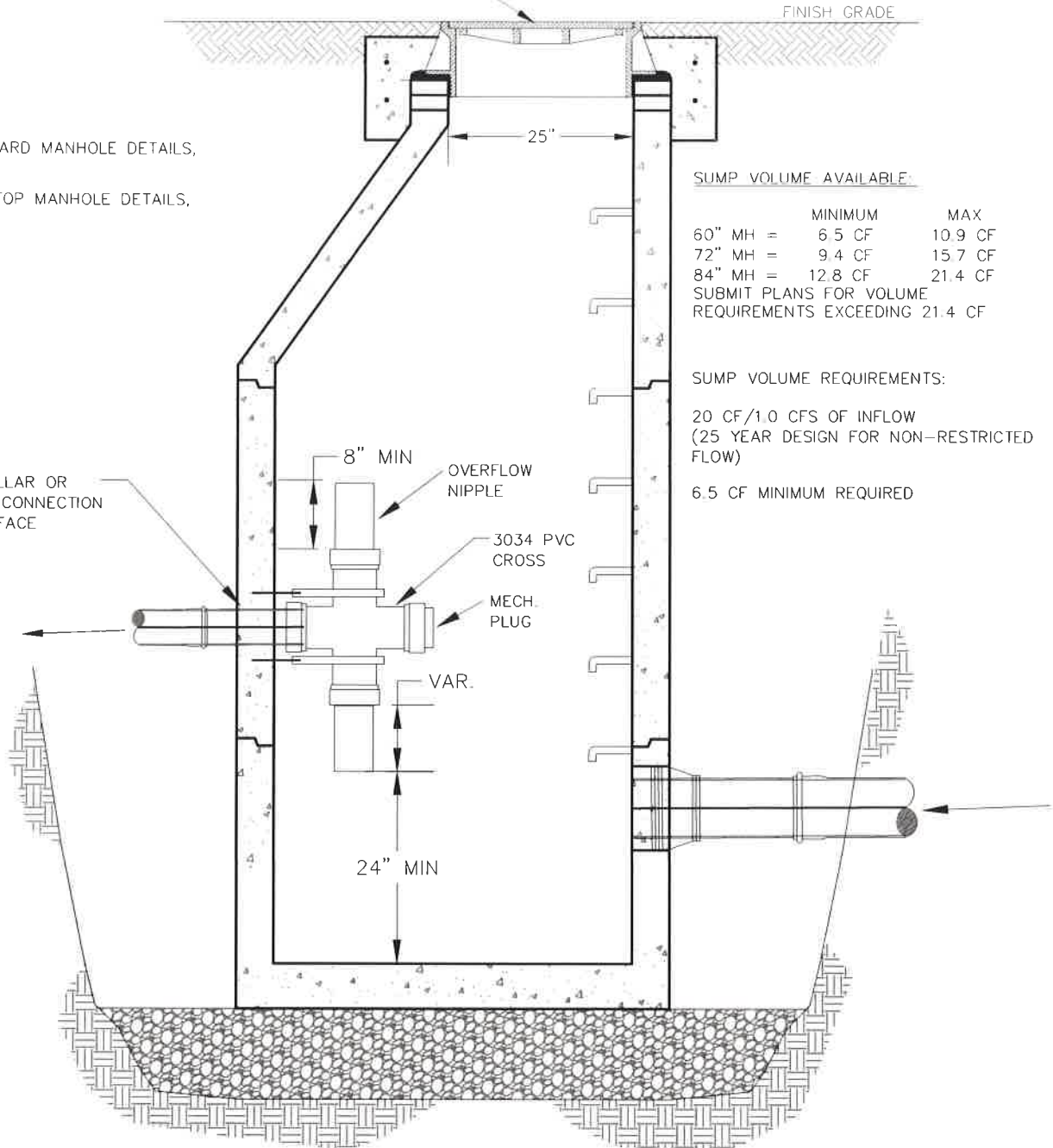

SUMP VOLUME AVAILABLE:

	MINIMUM	MAX
60" MH =	6.5 CF	10.9 CF
72" MH =	9.4 CF	15.7 CF
84" MH =	12.8 CF	21.4 CF

SUBMIT PLANS FOR VOLUME
REQUIREMENTS EXCEEDING 21.4 CF

SUMP VOLUME REQUIREMENTS:

20 CF/1.0 CFS OF INFLOW
(25 YEAR DESIGN FOR NON-RESTRICTED
FLOW)

6.5 CF MINIMUM REQUIRED

INSIDE DROP AND WATER QUALITY MANHOLES SHALL BE AT
LEAST 60" Ø WITH 42" OF CLEAR SPACE



City of Cave Junction
222 W. Lister Street
Jackson, Oregon 97523
(541) 592-2156

**STORM DRAIN POLLUTION
CONTROL MANHOLE**

DETAIL NO.

D-201

03/01/2021

AT SPRING LINE OF PIPE
EXTEND CHANNEL UP TO
CROWN LINE ON 12:1
BATTER (TYP)

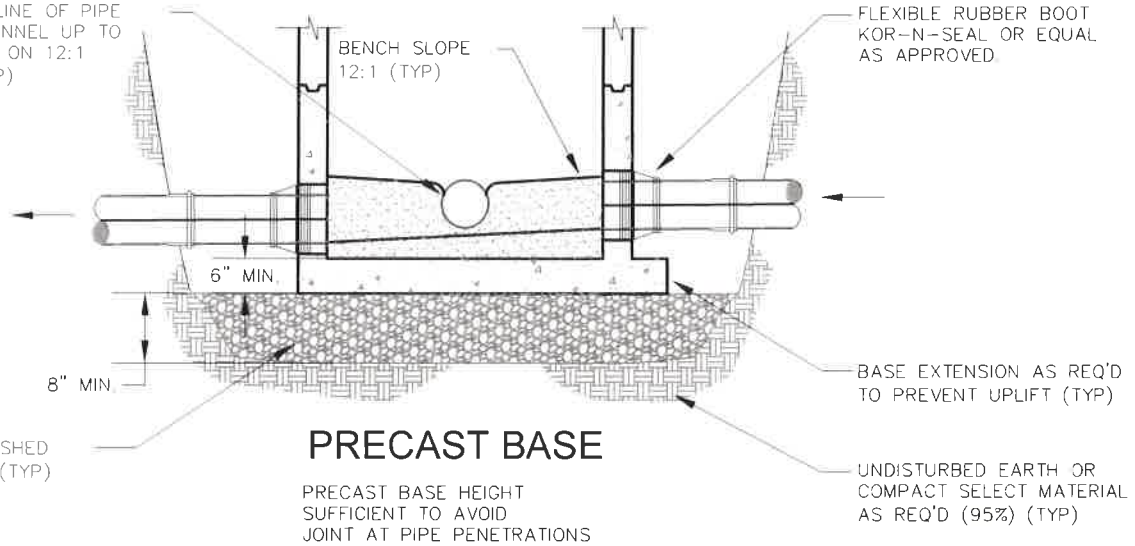

PRECAST BASE

PRECAST BASE HEIGHT
SUFFICIENT TO AVOID
JOINT AT PIPE PENETRATIONS

OR GREATER AS REQ'D
TO PREVENT UPLIFT

RAM-NEK SEAL

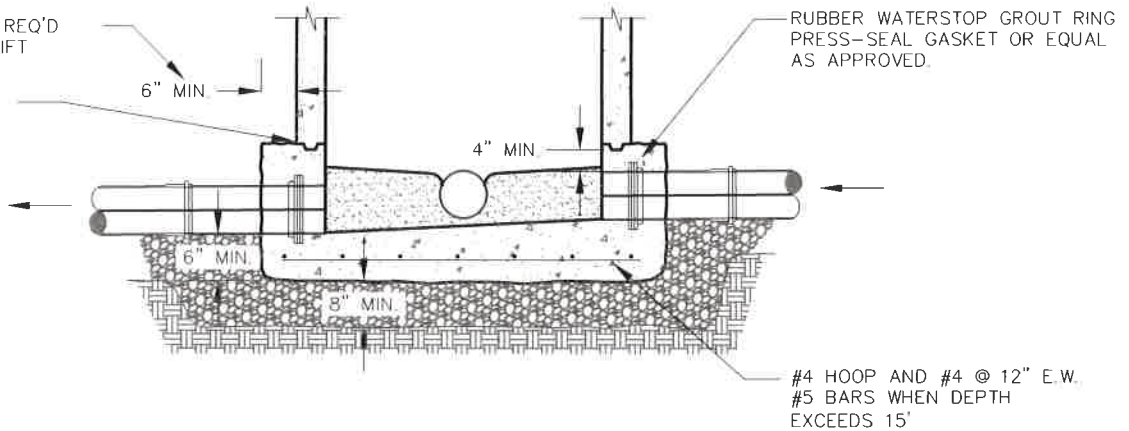

CAST-IN-PLACE BASE

CONTOUR TO PROVIDE
SMOOTH CHANNELS
SHAPE TO AVOID SOLIDS
DEPOSITION AND DIRECT
HEAD-ON FLOWS

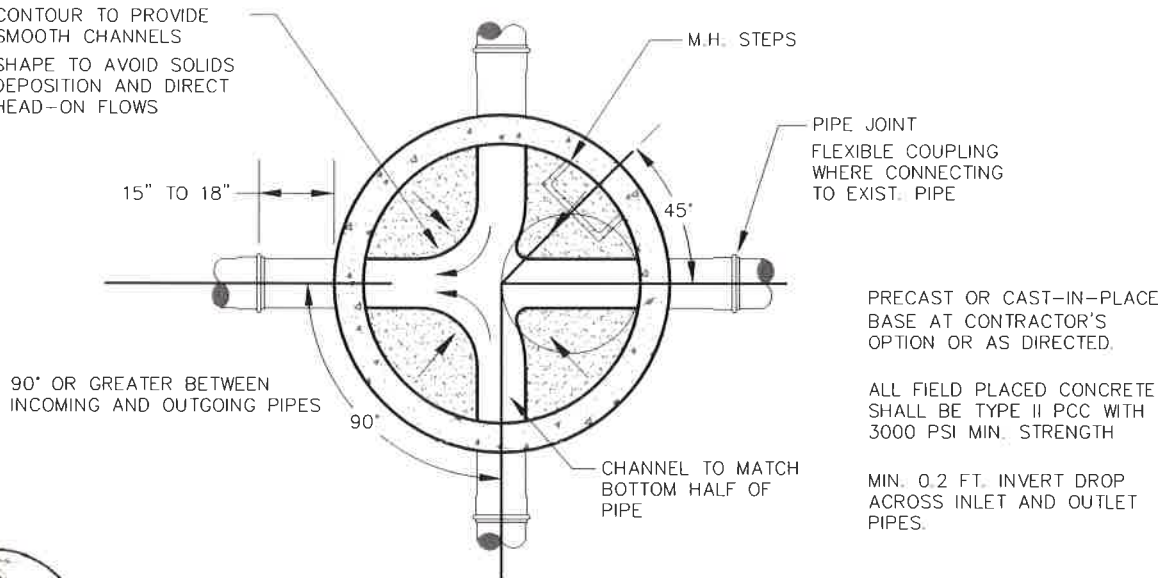

PRECAST OR CAST-IN-PLACE
BASE AT CONTRACTOR'S
OPTION OR AS DIRECTED.

ALL FIELD PLACED CONCRETE
SHALL BE TYPE II PCC WITH
3000 PSI MIN. STRENGTH

MIN. 0.2 FT. INVERT DROP
ACROSS INLET AND OUTLET
PIPES.



City of Cave Junction
222 W. Lister Street
Jackson, Oregon 97523
(541) 592-2156

MANHOLE BASE STANDARD DETAILS

DETAIL NO.

D-210

03/01/2021

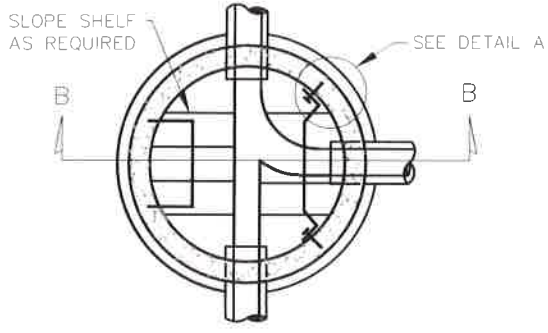

SECTION A-A

1/2" ϕ SELF TAPPING
 CONCRETE ANCHORS,
 PHILLIPS S-12 OR
 APPROVED EQUAL, w/
 1/2" ϕ x 1-1/2" Lg.
 STAINLESS STEEL
 BOLT & STAINLESS
 STEEL LOCK WASHER

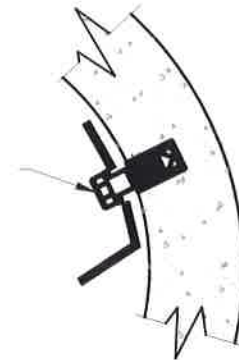

DETAIL A
 (PARTITION ATTACHMENT)

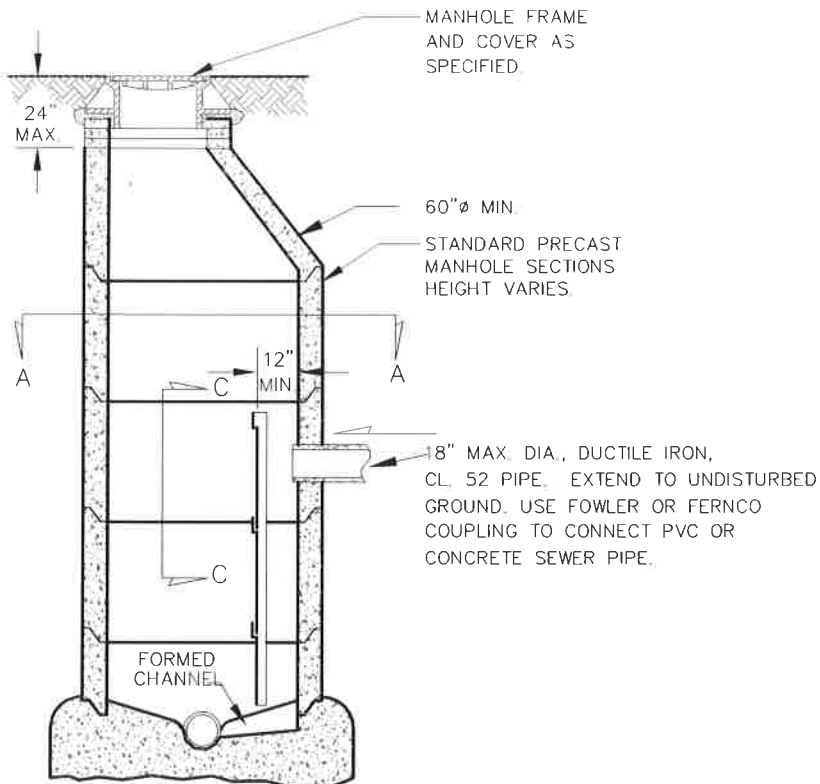

SECTION B-B

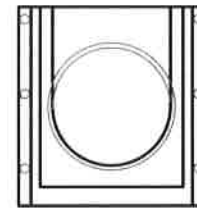

SECTION C-C

NOTES:

1. INSIDE DROP MANHOLES WITH DEFLECTION PLATE SHALL ONLY BE USED WITH PRIOR APPROVAL FROM CITY.
2. ONLY ONE DROP ASSEMBLY ALLOWED PER MANHOLE.
3. INSIDE DROP AND WATER QUALITY MANHOLES SHALL BE AT LEAST 60" ϕ WITH 42" OF CLEAR SPACE



City of Cave Junction
 222 W. Lister Street
 Jackson, Oregon 97523
 (541) 592-2156

**STANDARD INSIDE DROP M.H.
 W/ DEFLECTION PLATE**

DETAIL NO.

D-220

03/01/2021

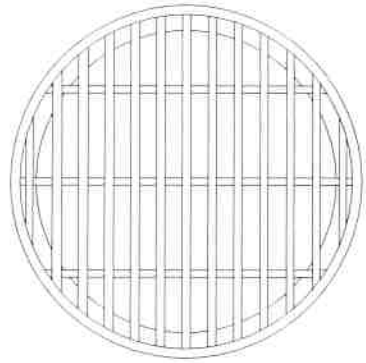

GRATE

(OLYMPIC FOUNDRY #MH26G,
OR APPROVED EQUAL)

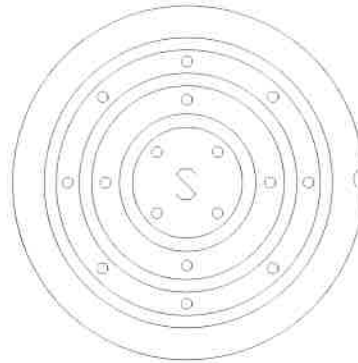

STORM

(OLYMPIC FOUNDRY #MH26P
OR APPROVED EQUAL)

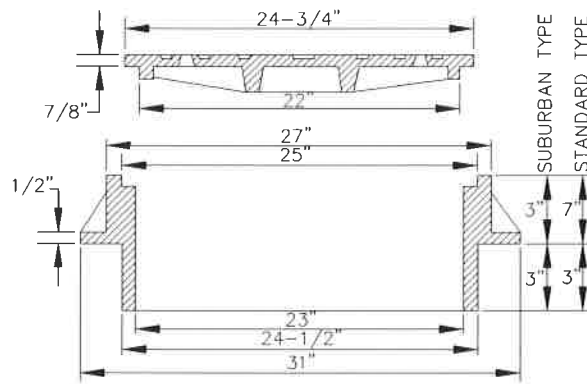

FRAME

(OLYMPIC FOUNDRY #MH26A,
OR APPROVED EQUAL)

NOTES:

1. USE SUBURBAN TYPE ONLY IN NON-TRAFFIC AREAS, AND ONLY WITH APPROVAL BY THE CITY.
2. COVER AND FRAME SHALL BE GRAY CAST IRON ASTM A-48 CLASS 30.
3. COVER AND FRAME TO BE MACHINED TO A TRUE BEARING ALL AROUND.
4. NOTCH LID FOR LIFTING HOOK.
5. OPEN GRATES REQUIRE APPROVAL BY CITY, AND MUST BE BICYCLE SAFE IF USED IN TRAFFIC AREAS.



City of Cave Junction
222 W. Lister Street
Jackson, Oregon 97523
(541) 592-2156

MANHOLE COVER AND
FRAME DETAILS

DETAIL NO.

D-250

03/01/2021

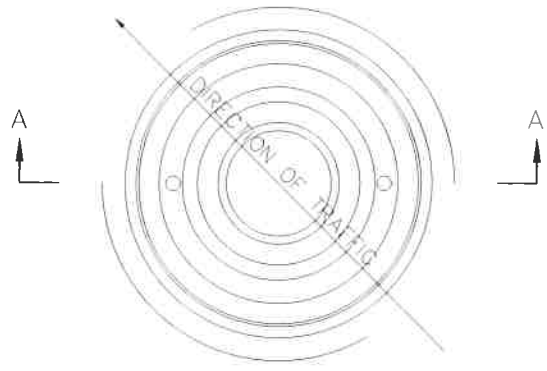

PLAN

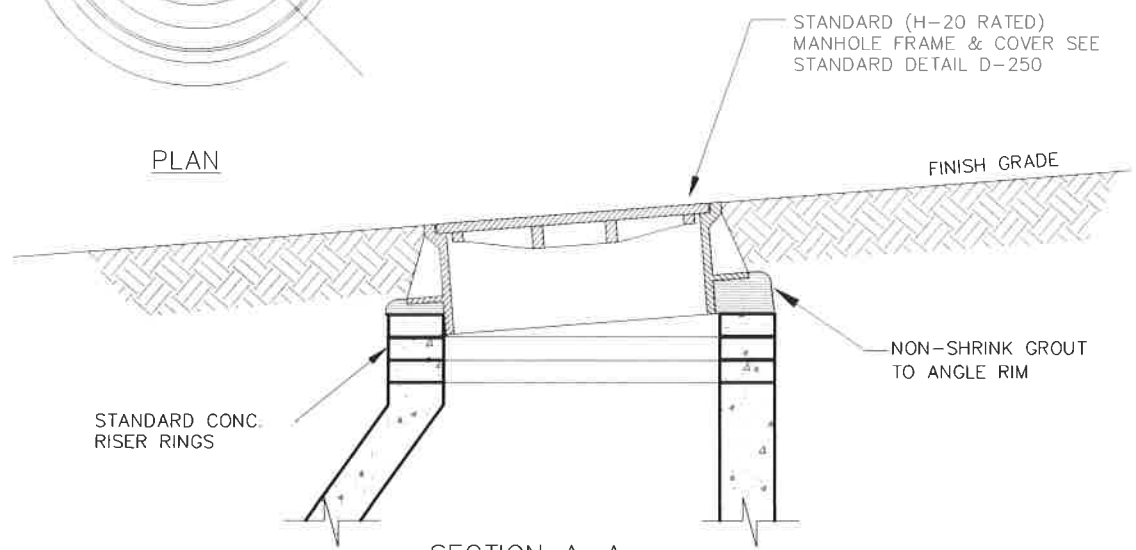

SECTION A-A
TYPICAL MANHOLE GRADE ADJUSTMENT IN STREET

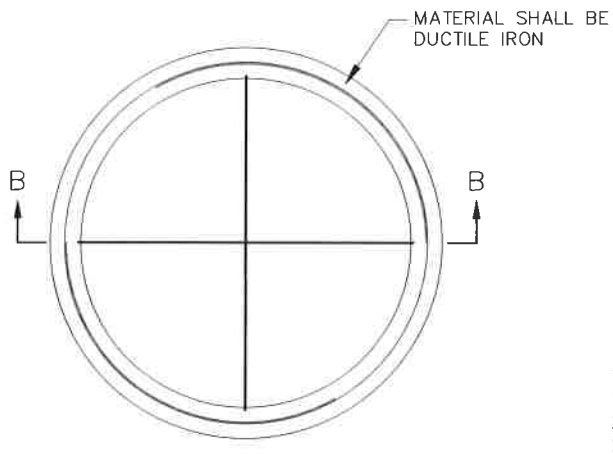

MANHOLE ADJUSTMENT RINGS
FOR RESURFACING

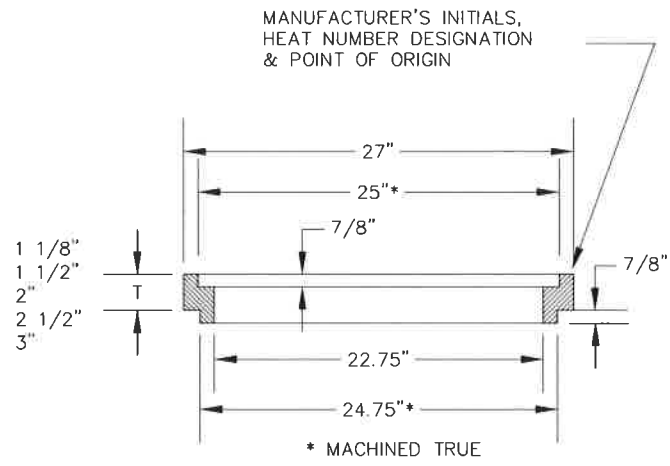

SECTION B-B



City of Cave Junction
222 W. Lister Street
Jackson, Oregon 97523
(541) 592-2156

MANHOLE FRAME
GRADE ADJUSTMENT

DETAIL NO.
D-260
03/01/2021

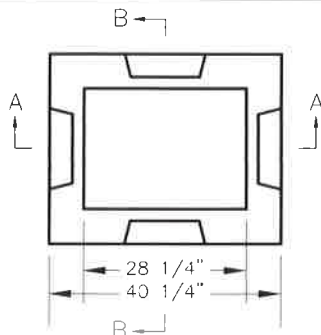

TOP VIEW

INLET TYPE	W	W1
G-1	2' 8-7/8"	1' 8-7/8"
G-2, G-2M	3' 3-3/8"	2' 3-3/8"

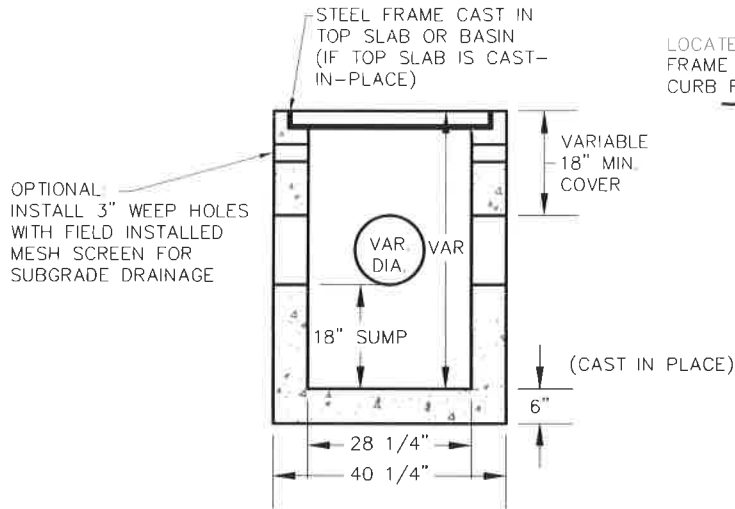

SECTION A-A

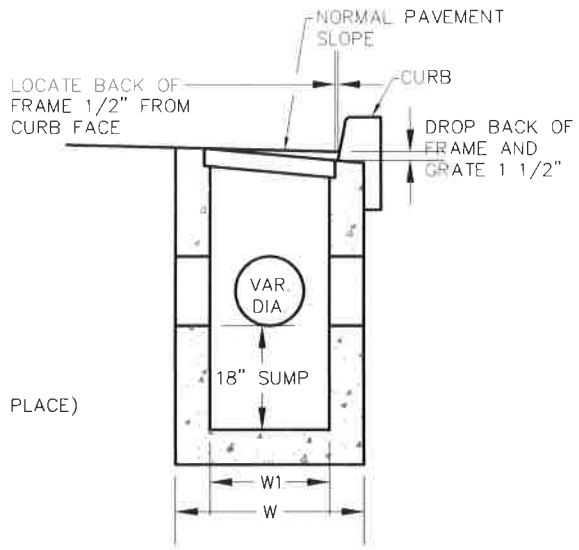

SECTION B-B

NOTES:

1. CONCRETE STRENGTH SHALL BE 3300 PSI.
2. PRECAST BASE WALLS SHALL BE A MINIMUM 4" THICK. CAST-IN-PLACE BASE WALLS SHALL BE 6" THICK.

TYPE	W	I/W
STANDARD	1'-9"	1'-8 1/4"

TYPE	DIA. PIPE	W	I/W
STANDARD	10"-12"	1'-10 3/4"	1'-9 3/8"

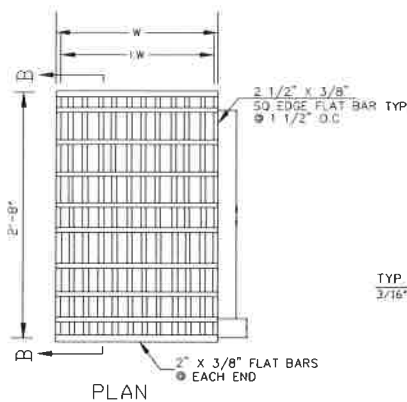

PLAN

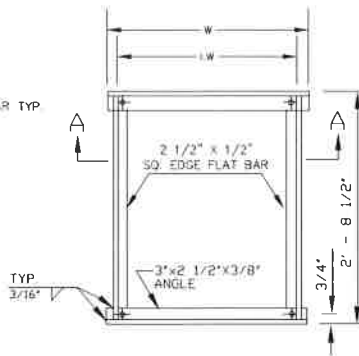

PLAN

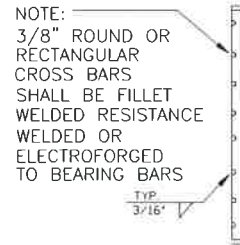

SECTION B-B

NOTE:

3/8" ROUND OR RECTANGULAR CROSS BARS SHALL BE FILLET WELDED RESISTANCE WELDED OR ELECTROFORGED TO BEARING BARS

TYP 3/16"

NOTE:
USE VERTICAL BEADS IN CORNERS, FILLET WELD JOINT ON BOTTOM OF FRAME. GRATE MUST REST FLAT ON

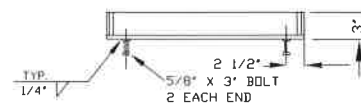

SECTION A-A'



City of Cave Junction
222 W. Lister Street
Jackson, Oregon 97523
(541) 592-2156

STANDARD INLETS,
FRAMES & GRATES

DETAIL NO.

D-300

03/01/2021

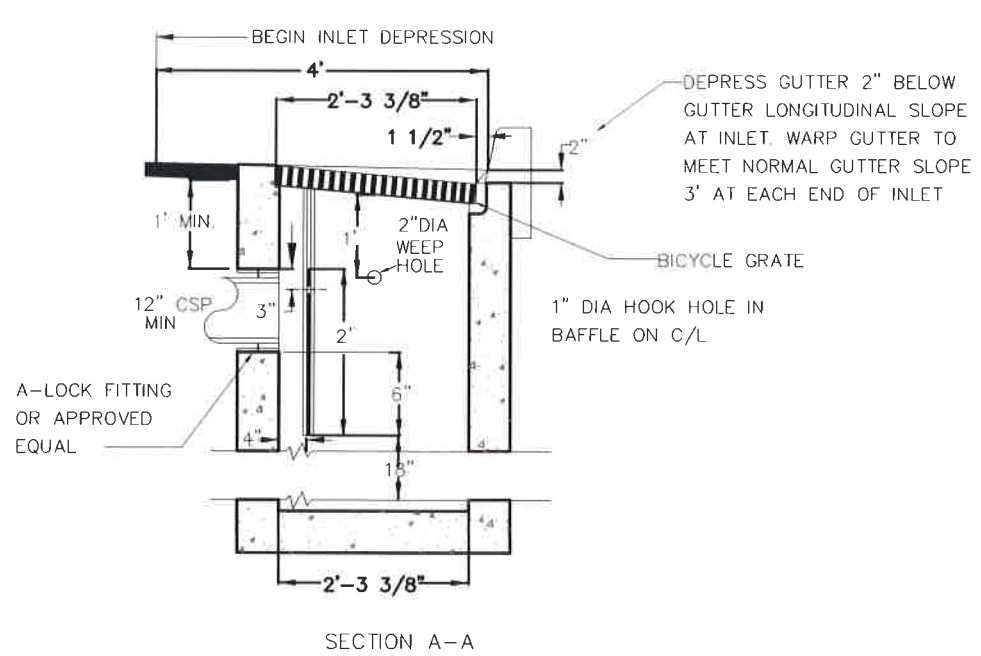
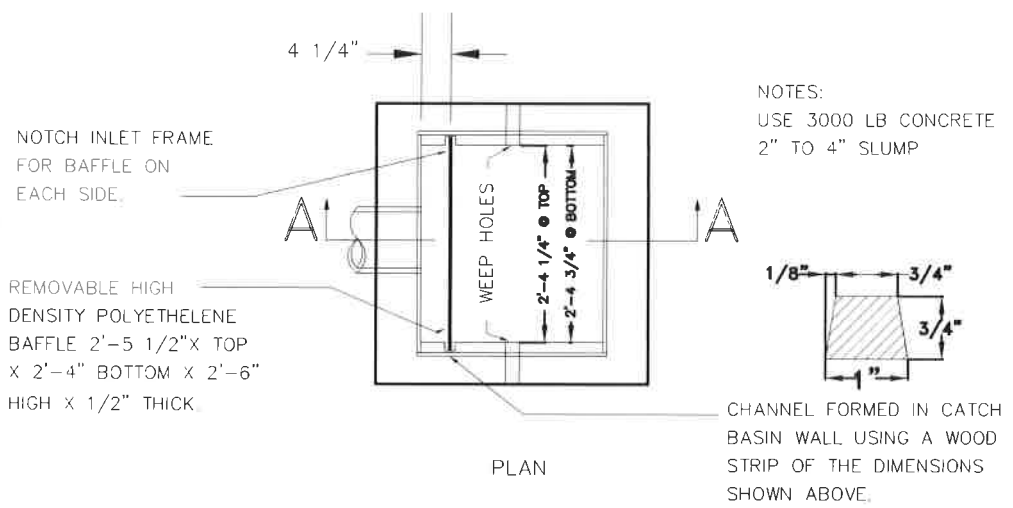

City of Cave Junction
222 W. Lister Street
Jackson, Oregon 97523
(541) 592-2156

TRAPPED/POLLUTION
CONTROL CATCH BASIN

DETAIL NO.
D-301
03/01/2021

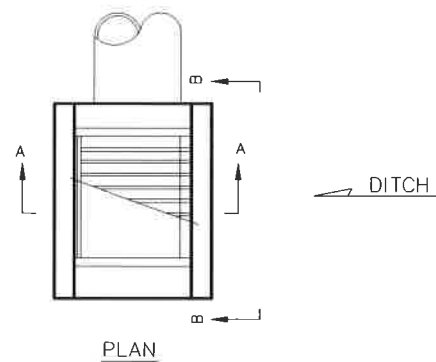
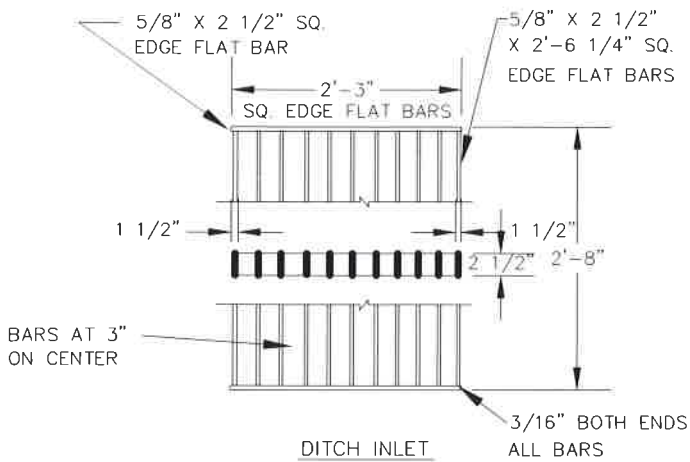
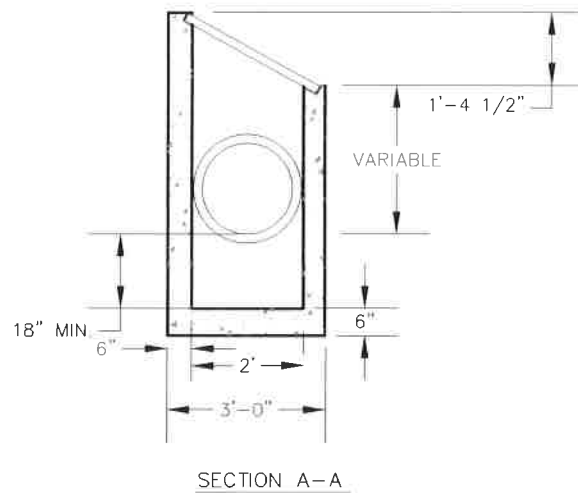
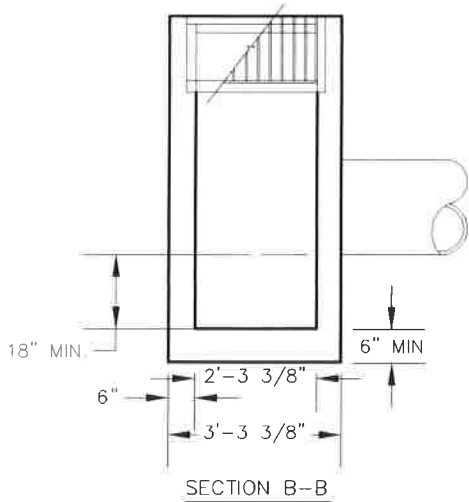

NOTES:

1. CONCRETE STRENGTH SHALL BE 3300 PSI.
2. CATCH BASIN, FRAME, AND GRATES SHALL MEET H₂O LOADING.
3. INSIDE FRAME DIMENSIONS: 2'-3 3/8", 2'-8 1/2"
4. 3/8" CROSS BARS SHALL BE FLUSH WITH THE GRATE SURFACE AND MAY BE FILLET WELDED, RESISTANCE WELDED OR ELECTROFORGED TO BEARING BARS.
5. DITCH INLET CATCH BASINS SHALL MEET THE REQUIREMENTS OF ODOT DITCH INLET TYPE "D"



City of Cave Junction
 222 W. Lister Street
 Jackson, Oregon 97523
 (541) 593-2156

TYPICAL DITCH INLET
 AND GRATE

DETAIL NO.

D-302

03/01/2021

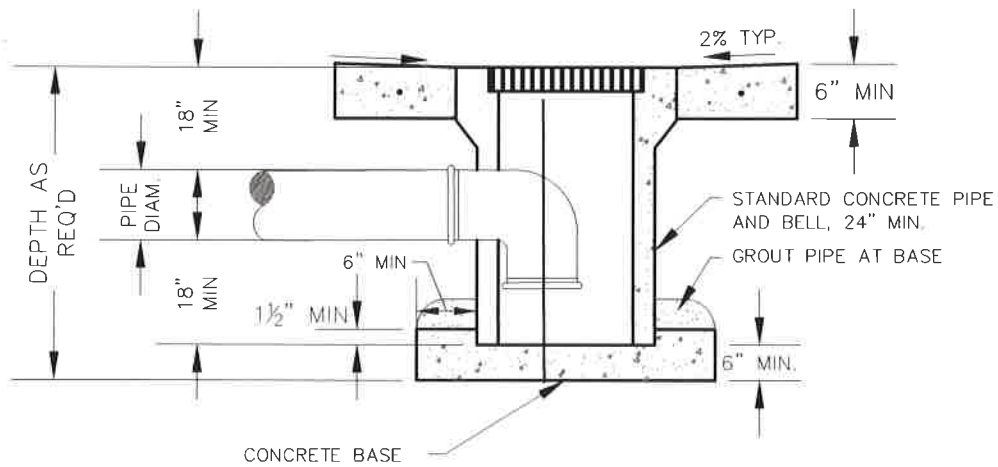
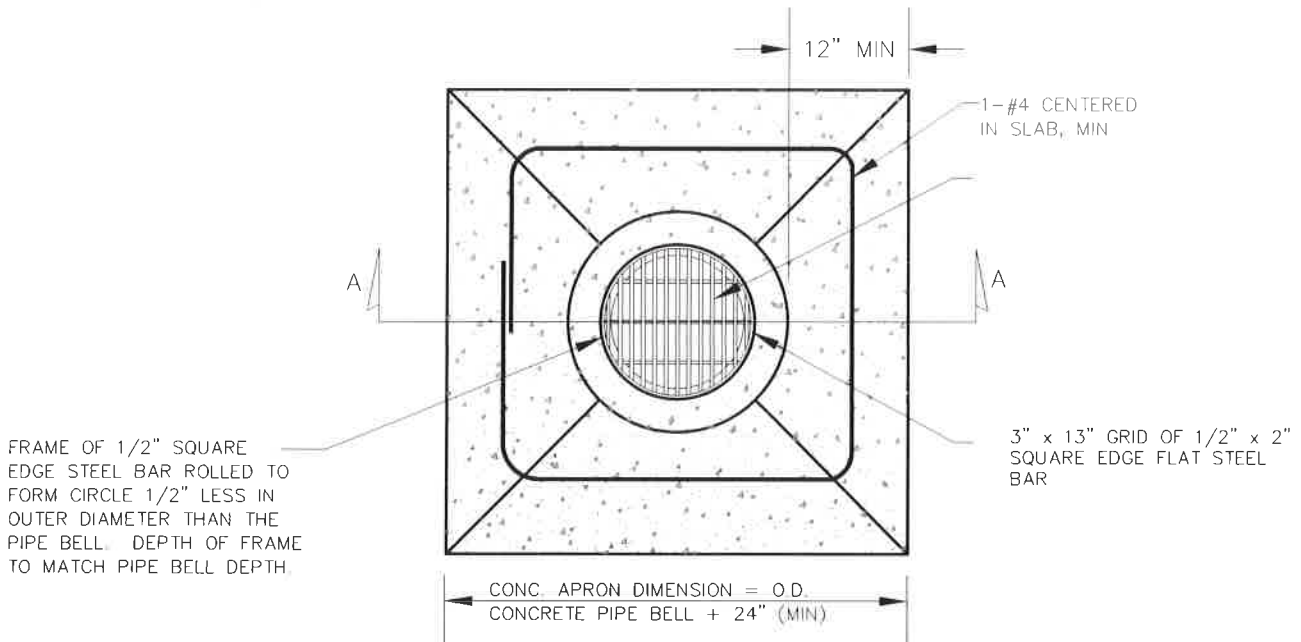

NOTES:

1. GRATES SHALL BE CONSTRUCTED FOR BICYCLE SAFETY.
2. PRECAST CONCRETE CATCH BASINS MAY BE USED FOR AREA DRAINS WHEN APPROVED BY THE CITY.
3. NOT FOR USE IN VEHICULAR TRAFFIC AREAS.



City of Cave Junction
 222 W. Lister Street
 Jackson, Oregon 97523
 (541) 592-2156

TYPICAL AREA DRAIN INLET

DETAIL NO.

D-303

03/01/2021

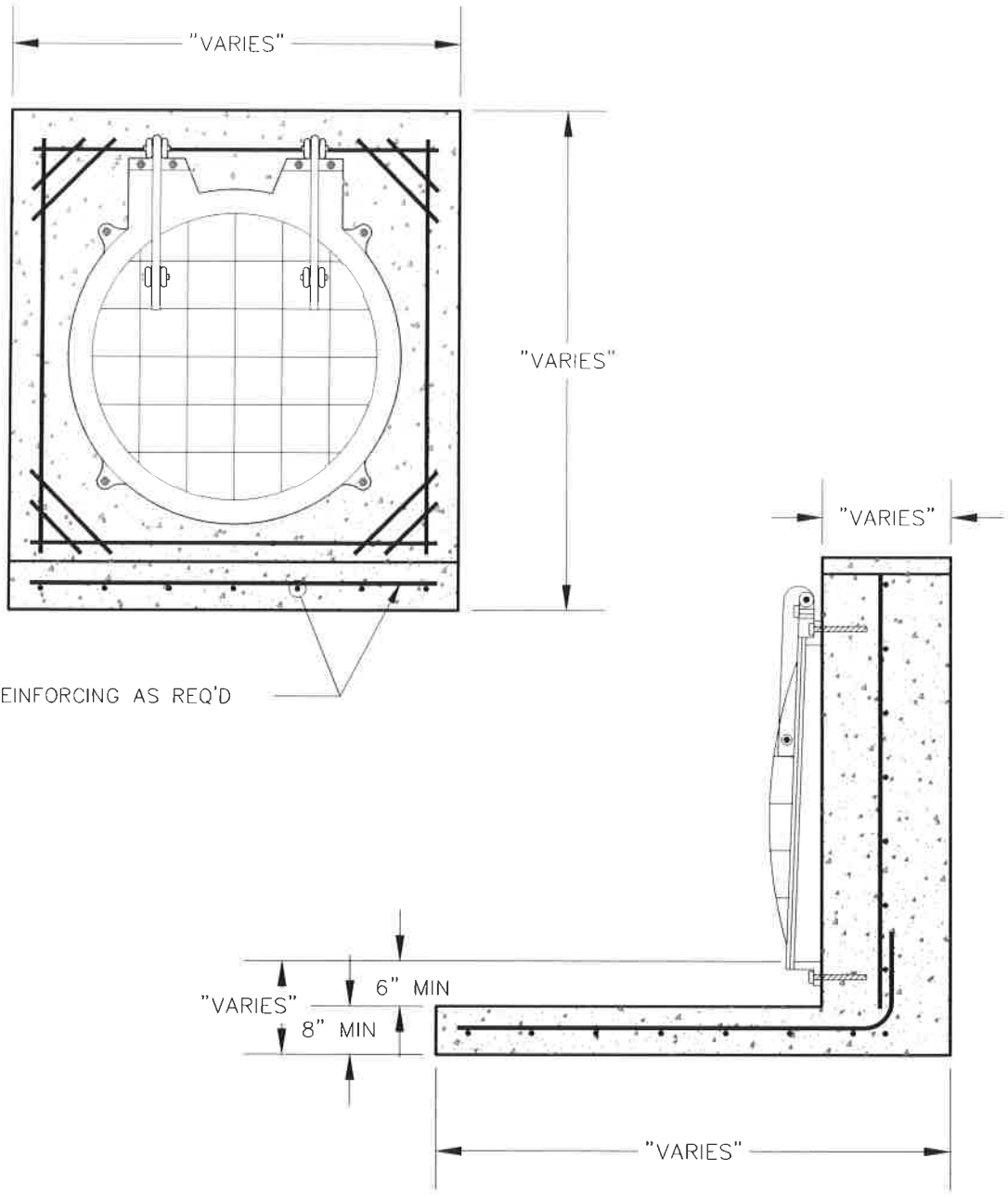

REINFORCING AS REQ'D

NOTE:

- 1) OUTFALL HEADWALL SHOWN FOR CLARITY ONLY – ALL OUTFALLS SHALL BE SITE SPECIFIC AND SHALL CONFORM TO THE REQUIREMENTS OF ALL FEDERAL, STATE AND LOCAL REGULATIONS.
- 2) OUTFALL SHALL BE ABOVE THE MEAN LOW WATER LEVEL EXCEPT AS APPROVED BY CITY ENGINEER. INSTALLATION OF TIDEGATE MAY BE REQUIRED WHEN OUTFALL IS IN A TAILWATER CONDITION.
- 3) ALL TIDEGATES, FLAPGATES OR OTHER OUTLET GATES INSTALLED ON SPECIFIC OUTFALLS SHALL MEET THE REQUIREMENTS OF ODFW, NOAA AND OTHER AGENCIES AS REQUIRED.
- 4) CONCRETE STRENGTH SHALL BE 3,300 PSI AFTER 28 DAYS.
- 5) PROVIDE REINFORCING AS REQUIRED.



City of Cave Junction
 222 W. Lister Street
 Jackson, Oregon 97523
 (541) 592-2156

HEADWALL WITH TIDEGATE

DETAIL NO.
D-304
03/01/2021

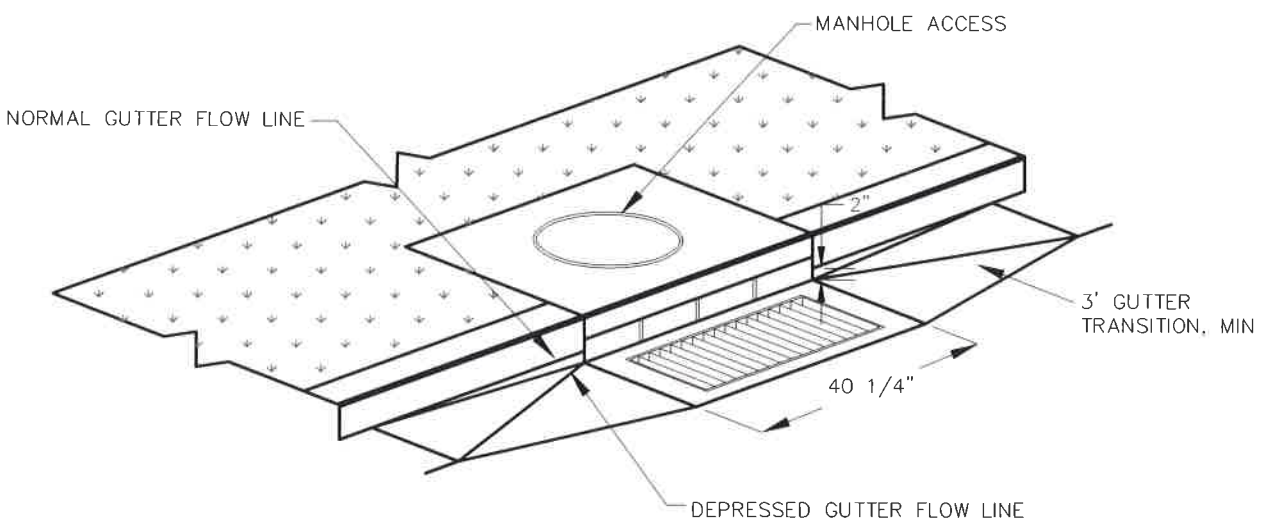
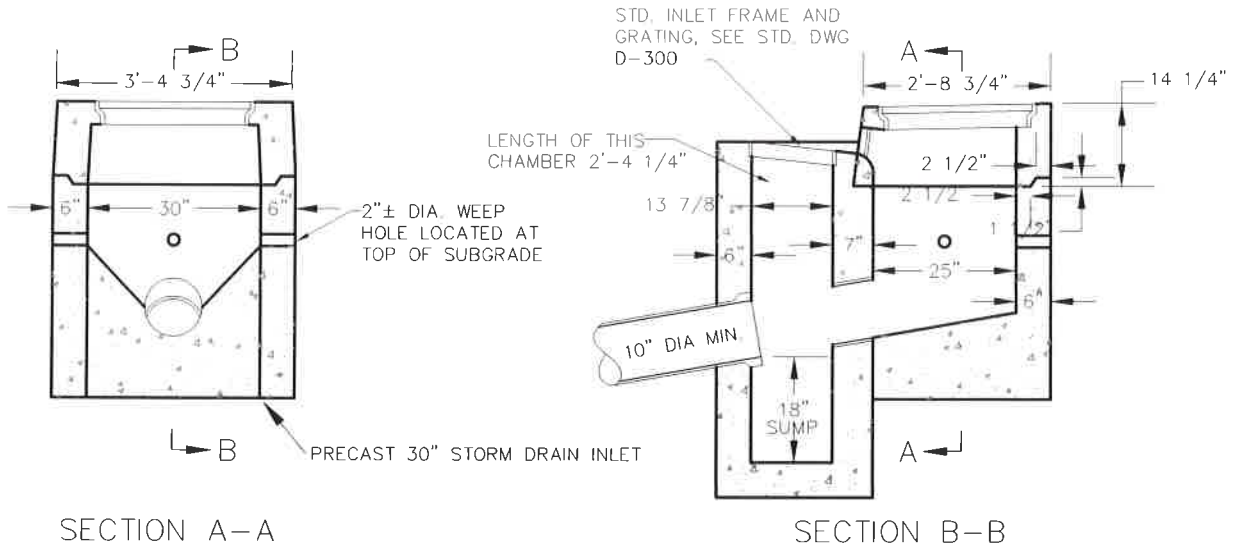

NORMAL PAVEMENT GRADE.

CAST IN PLACE CONCRETE TO BE 3300 PSI, 3" TO 5" SLUMP

NOTE:
 PRECAST TOP SLAB SHOWN WITH GUTTER TRANSITION FLARE IF THE TOP SLAB IS CAST-IN-PLACE, NO FLARE IS REQUIRED IN THE TRANSITION SECTION; MATCH THE TOP FRONT EDGE OF THE FRAME AND THE TOP FRONT EDGE OF THE CAST-IN-PLACE TOP SLAB TO THE



City of Cave Junction
 222 W. Lister Street
 Josephine, Oregon 97523
 (541) 592-2156

COMBINATION CURB INLET

DETAIL NO.
D-305
03/01/2021