



*JOSEPHINE COUNTY, OREGON*

**DIVISION 2:**  
**SANITARY SEWER DESIGN STANDARDS**  
**MANUAL**  
**Guidelines for Development**

**Effective: March 1, 2021**

---

---

**Section 1 – General Design Requirements**

- 1.1 The purpose of this manual is to set standards for the design and construction of sanitary sewer system improvements to serve new and future development. This manual may be updated periodically and the design engineer shall ensure that they have the latest version.
- 1.2 Storm water, including street, roof, or footing drainage shall not discharge into the sanitary sewer system.
- 1.3 Upon receiving approval from the City for the plans and specifications, the developer shall submit the plans to the Oregon Department of Environmental Quality for review and approval. The developer will submit proof of DEQ approval of the plans to the City prior to beginning any construction activities.

**Section 2 – Design Plan Format**

- 2.1 Engineering plans and specifications shall be prepared for all public works improvements. Plans shall be clear and legible and show all improvements in sufficient detail to allow for determination of compliance with City standards, and proper field construction. City engineer or City representative may require additional detail if deemed necessary.
- 2.2 Plan views must show existing and proposed improvements and features within or adjacent to the project including survey monuments, edge of pavement, road centerline, buildings, curbs, gutters, sidewalks, culverts, ditches, streams, utility poles, and other surface improvements and features. The location of underground utilities including power, gas, water and sewer shall be shown as accurately as possible. Right-of-way, property lines, easements, street names, lot numbers, and other labels shall also be shown. Existing and finish grade contours (2 foot maximum) should be shown where possible.
- 2.3 Plan shall show the location, stationing, and size of all sewer mains and services including appurtenances such as manholes, clean-outs, tees, and wyes. Stationing shall be called out for specific items to be installed. Matchlines shall be used when continuing to other sheets.
- 2.4 Profile view with stationing and elevation shall be provided for sewer mains. Profile shall show existing ground, finish grade, invert and manhole rim elevations, backfill class materials, pipe size and slope, and all existing and proposed utilities crossing the profile. Profile shall be generated along the sewer pipe centerline. Vertical separation shall be shown for crossing utilities.
- 2.5 Detail drawings shall be provided for typical trench sections, manholes, clean-outs, sewer service laterals, and others as required.
- 2.6 Refer to the City’s “Engineering Policy – Guidelines for Development” document for additional requirements and submittal procedures.

### Section 3 – Sanitary Sewer System Design Requirements

- 3.1 All sanitary sewers and facilities shall be designed, submitted, reviewed, and constructed in accordance with Oregon DEQ guidelines and City standards. Developer's engineer should review OAR 340-052, DEQ Sanitary Sewer Design Notes dated 1994, OAR 340-052 Appendix A dated 1981, DEQ Standards for Design and Construction of Wastewater Pump Stations dated May 2001, and other guidelines as applicable. See Oregon DEQ's website for guidance manuals <http://www.deq.state.or.us/wq/wqrules/Guidance.htm>
- 3.2 Minimum size for new sewer mains is 8-inches unless otherwise approved. Hydraulic calculations shall be performed to ensure that pipe size is adequate for conveying peak instantaneous flows at full development of any subdivision with pipe flow no more than 80% full depth. Capacity shall be based on Manning's Equation with "n" = 0.013 and pipe flowing at full depth. Minimum slopes required are shown in the table below. Slopes for larger gravity sewers shall be calculated so as to provide a velocity of at least 2.0 ft/sec flowing full or half full.

Pipe I.D. (inches)	Minimum Slope (ft drop per ft length)	Capacity (gpm)
6	0.006	219
8	0.0040	344
10	0.0028	540
12	0.0022	786
15	0.0017	1200

- 3.3 Sewers with minimal flow such as upper reaches of laterals serving few dwellings shall be steepened to provide a 2.0 ft/sec velocity. Actual flows during initial years of use shall be carefully evaluated in this regard.
- 3.4 Pipe size shall not be increased larger than necessary for capacity in order to meet grade requirements, e.g., 10-inch pipe used instead of 8-inch to allow decreased slope.
- 3.5 Flows used in design calculations shall be in conformance with acceptable standard practice. For dwellings, a flow of 100 gpcd shall be used (includes normal infiltration) as a design basis for average daily flow. A peaking factor of 3.5 shall be applied for peak instantaneous flows. When requested, Engineer shall submit to City the design calculations used for sizing the proposed sanitary sewer system.
- 3.6 Public sewerage facilities shall be designed to allow the logical service of all parcels or tracts of land within the basin being considered. Sewer lines shall be sized and extended, at the owner's or developer's expense, to all adjacent parcels approximately equal to or higher in elevation to facilitate future development.
- 3.7 Minimum depth of cover is normally 63-inches over top of pipe barrel for gravity sewer mains (based on providing 18-inch vertical separation below an 8-inch water line with 36-inch cover). Shallower depths may be allowed providing at least 18-inches of vertical separation is provided at all water main and water service crossings.

- 3.8 Sanitary sewer piping shall be located 10 feet horizontally away from any parallel water main or service when possible. All water line and sewer line shall be separated in accordance with OAR 333-061-0050 provisions.
- 3.9 No private sanitary sewer shall be located within any lot other than the lot which is the site of the building or structure served by such sewer. Exceptions may include common areas in planned unit developments, and public right-of-ways as approved by the City. Each lot shall have its own service lateral. Shared service laterals are not allowed.
- 3.10 Service laterals shall not be connected to manholes unless approved by City Engineer for special conditions such as cul-de-sacs, etc. Connection shall be to gravity sewer pipe in an approved manner. Service laterals shall be new PVC Tees with manufactured bends (Wyes) to the main as shown on the standard details. A clean-out is required on the service lateral in the public right-of-way or easement in accordance with the standard detail. An additional clean-out must be provided at least every 100 feet on the private lateral portion as per the Uniform Plumbing Code.
- 3.11 For pipe placed on slopes steeper than 15%, restrained joint pipe or joint restraint devices shall be installed.
- 3.12 Sewers shall be located in the right-of-way at the street centerline or within 5 feet from centerline, but outside of the traveled wheel lane. Location of sewers skewed across streets where disruption of curbs, gutter or sidewalks would be required for future exposure of the main is prohibited. Sewers in easements will only be allowed after all reasonable attempts to place mains in the right-of-way have been exhausted. Sewer easements shall be a minimum of 15 feet wide with wider easements required for sewers greater than 8 feet deep such that a 1:1 theoretical slope from pipe centerline would daylight within the easement.
- 3.13 Manholes
- 3.13.1 Manholes shall be spaced no greater than 400 feet apart, and shall be provided at every change in grade or alignment, every change in pipe size, at every intersection or junction, and at the upper end of a sewer lateral. Curved sewers are not allowed.
- 3.13.2 No manhole shall be placed where future maintenance access cannot be assured. A hard all-weather surface (AC, concrete, or gravel) capable of supporting a 48,000 pound truck shall be constructed (ex.: bikepath) to provide access to manholes in common areas or parks.
- 3.13.3 Clean-outs will not be substituted for manholes. An exception may be when a section of pipe is extended less than 250 feet to serve 5 or fewer single-family dwellings and no potential for future extension exists. In this case, a permanent clean-out may be provided at the end of the pipe. The pipe may also be 6-inch diameter. Such installations will only be allowed in special cases upon prior approval from the City Engineer.

- 3.13.4 Manhole channels shall be designed for self-cleaning with a minimum drop of 0.2 feet (2.4 inches) from invert in to invert out along a smooth flow channel. Channel width and depth shall be equal to the pipe diameter.
- 3.13.5 Intersecting sewers and connections shall be designed to avoid backup into the smaller sewer. For intersecting unequal sized sewers in manholes, the water surface elevation at 0.8 of full depth of flow in each sewer pipe shall match. Manhole base channels shall be formed to ensure smooth flow without head-on intersection of opposing flows.
- 3.13.6 Free fall of sewage into a manhole shall not exceed 24 inches without a special drop manhole. Standard manholes without free fall are preferred although drop manholes may be considered when a considerable amount of additional excavation would be required to construct pipes/manholes without drop.
- 3.13.7 Where future extensions are planned or likely, stub-outs shall be provided with watertight rubber-gasketed plugs adequately braced against air test pressures. Stub-outs shall be adequately sized as approved. Stub-outs shall be sufficiently long to extend to the limits of new construction or surface improvements. A temporary cleanout shall be installed on the stub-out at the phasing line unless otherwise approved by City Engineer.
- 3.13.8 Manholes shall be located outside the normal wheel travel lanes. Manhole lids are not permitted within designated or future bike lanes. Manholes shall not be located in the curb or gutter. Manholes in sidewalks are not allowed unless otherwise approved by the City.
- 3.13.9 Watertight manhole covers shall be used when the cover is below the 100-year flood plain or in a location where overland runoff could enter the manhole. Locking, tamper-proof covers are required in easements and off street areas. Must have adaptation for manhole lid pullers.
- 3.14 Pump Stations and Force Mains
- 3.14.1 Sewage pump stations shall only be provided when gravity service cannot be practically provided. Prior approval from the City is required.
- 3.14.2 Pump stations shall have concrete wetwells with approved self-cleaning bottom designs. Pumps shall be submersible type with stainless steel rails and hoist for easy removal. EPA Class I reliability is required, including a standby generator. A separate check valve and flow meter vault(s) is required. A heated and ventilated building or approved enclosure shall be included for the controls and electrical equipment. At a minimum, a covered and fenced area shall be provided to protect standby generator from the elements.
- 3.14.3 Design shall be in accordance with DEQ guidelines and as directed by the City. A pre-design report is required and shall be approved by the City. Following City approval, the pre-design report must be approved by DEQ.

- 3.14.4 Force mains shall be 4-inch minimum and designed to provide a minimum velocity of 3 feet per second. Force mains shall terminate at an approved location and in an approved manner. Surge control measures may be required.
  - 3.14.5 Telemetry and SCADA systems are required at pump stations. Telemetry systems must be compatible with existing City systems or of an approved design that will allow compatibility with future or planned systems.
  - 3.14.6 Coordinate with the City for specific requirements and approved materials and equipment prior to commencing with pre-design report.
- 3.15 Individual Grinder Pump Installations
- 3.15.1 Individual buildings may include individual grinder pump stations when gravity service cannot be made available and a public pump station is not warranted or required by the City. Such installations will generally be limited to fewer than 4 single family dwellings within a development and may only be allowed upon prior approval upon a determination that gravity service is not possible.
  - 3.15.2 Each pump shall be its own individual pressure line from the pump to the public gravity main. Pressure line shall be PVC or HDPE with a 200 psi pressure rating. Connection to gravity main shall be made with an approved saddle, ball check and corporation stop as directed by the City. Connections to manholes are not allowed unless approved by the City Engineer. Pressure mains shall have a minimum of 18-inch vertical separation under all water lines. Pipe size shall be 1¼-inch or as recommended and designed by the pump manufacturer.
  - 3.15.3 Grinder pump systems will be owned and maintained by the private property owner.
- 3.16 Septic Tank Effluent Pumping (STEP) and Septic Tank Effluent Gravity (STEG) systems are not permitted within the City Limits unless otherwise approved.
- 3.17 Oil/Water Separators are required for all facilities (gas stations, parking structures, etc.) where there is the potential for discharge of oily, contaminated waters in the sewer system. No grease, oil, sand, liquid waste containing grease or flammable material or other harmful ingredients shall be discharged into any public sewer. Location shall be on private property. Installation, operation and maintenance shall be by the property owner. Design shall be approved by the City with documentation of maintenance schedule to be submitted to the City.
- 3.18 Grease Interceptors are required for all commercial buildings with kitchen and/or cafeteria facilities or other facilities where excessive discharge of animal fats or vegetable oils can occur. Sizing of the interceptor shall be in accordance with the latest edition of the Uniform Plumbing Code and as approved by the City prior to installation. Location shall be on private property. The owner of the grease generating establishment shall install, operate and maintain the properly sized and designed grease interceptor tank. The interceptors shall be regularly pumped or cleaned out and maintained to ensure that they operate properly.

- 3.18.1 See Uniform Plumbing Code – Grease Interceptor Sizing Worksheet.
- 3.19 All details shall conform to the Standard Detail Drawings. Required items or installations for which no detail drawing exists, applicant's engineer shall submit sufficient design data and drawings for City approval. All such submitted drawings may require modification prior to approval for use.
- 3.20 Eleventh month inspection is required. Eleven months after the project is completed, all facilities constructed as part of the project will be inspected. Developer and/or Developer's Engineer shall be present. All gravity sewer lines will be video inspected per Section 11. All defects will be corrected at the Developer's expense.

#### **Section 4 – Construction Provisions**

- 4.1 All work within the public right-of-way shall be conducted by a licensed and bonded contractor. This requirement shall be stated on the construction drawings and in the project specifications.
- 4.2 City shall be notified at least 3 working days in advance prior to commencing construction work exception shall be made for emergency repairs.
- 4.3 Traffic control shall be signed, flagged and conducted in a manner conforming to ODOT standards (Manual of Uniform Traffic Control Devices, MUTCD) and approved by City. If road closures or detours are anticipated, prior approval from City and/or ODOT, must be obtained, as appropriate.
- 4.4 Safety Requirements. The contractor is responsible for observing the safety of the work and all persons and property coming into contact with the work. The contractor shall conduct his work in a manner complying with the requirements prescribed by OSHA.
- 4.5 Progress. Construction shall proceed in a systematic manner to minimize public inconvenience and disruption of services. All excavations, embankments, stockpiles, waste areas, etc. shall be kept protected. All roads, ditches, etc. shall be kept free from debris and shall be continually cleaned during the work. Dust control measures shall be employed as required and directed by the City.
- 4.6 Protection of Existing Improvements. Contractor shall contact the Utility Notification Center at least 48 hours in advance of digging operations to get approximate locations for buried utilities. Exact locations of buried facilities may not be known or shown and contractor is responsible to pot-hole carefully in advance of the work to avoid such facilities. Contractor shall coordinate with all utilities and notify them immediately in the event of any damage. Contractor shall protect, repair, and replace any damaged utilities as directed by the persons responsible for such utility. All landscape, grass, shrubs, signs, pavements, mail boxes, driveways, culverts, gravel surfacing, fencing, etc. shall be protected from damage and returned to conditions as good, or better than existed prior to construction. All costs for protection, repair, and replacement of all existing items shall be borne entirely by the contractor. Contractor shall obtain a release from any property owners for any claims of injury or property damage prior to final acceptance of the work by the City.

- 4.7 All existing survey monuments and control shall be protected, including individual property corner stakes. Any such monuments destroyed or altered during construction shall be restored by the contractor or developer in accordance with ORS.
- 4.8 Any temporary disruption to water or sewer service must be coordinated with, and approved by the City and kept to the minimum length of time necessary. City shall be notified at least 2 working days in advance of when an approved shut-down is desired as necessary to make tie-ins.
- 4.9 Trench foundation grades shall be constructed to within 0.1 feet of the grade shown in the plans. Surface tolerances shall be within 0.02 feet of plan elevation at any one point.
- 4.10 For pipelines, vertical deviation from true grade shall not exceed 0.02 feet (0.24 inch). Horizontal tolerance for deviation from line shall be 0.03125 feet (3/8 inch). Depressions or bellies which create the potential for solids deposition are not allowed.
- 4.11 Compaction testing equipment (nuclear gauge) shall be furnished and operated by the contractor or an independent testing firm shall be retained by the contractor or developer to perform compaction testing. Testing shall conform to the ODOT Manual of Field Testing Procedures (MFTP). Compaction testing shall be conducted in the presence of the City's inspector. Sufficient tests will be taken to ensure that the materials and compaction efforts being used are adequate to obtain the required density. Several tests shall be taken on each lift placed during the first day of backfill operations. Additional tests will be taken periodically during the work. At minimum, 2 compaction tests shall be taken for each trenchline (manhole to manhole). Alternate materials or methods will be required if adequate compaction is not being obtained. In no case shall pipe laying continue if inadequate compaction results until a resolution is provided.
- 4.12 Construction staking will be provided by the Developer's Engineer for establishing the location of the system. Offset stakes shall be placed at no more than 100 foot intervals along the mainline at each manhole. Each lateral location shall be staked.
- 4.13 Open trench length at any time shall not exceed 100 feet unless otherwise approved. Related resurfacing shall be completed within 800 feet of the open trench limit.

#### **Section 5 – Sanitary Sewer System Materials**

- 5.1 All materials shall be manufactured in the USA and be newly manufactured. No rebuilt, reconditioned or used material will be allowed.
- 5.2 Oregon Standard Specifications (OSS) – Means the 2002 Oregon Standard Specifications for Construction produced by ODOT and APWA, including latest revisions.
- 5.3 Concrete shall conform to OSS Section 00440, Commercial Grade Concrete. Compressive field strength shall not be less than 3,000 psi at 28 days. Maximum aggregate size shall be 1½-inches. Slump shall be between 2 and 4 inches.
- 5.4 Non-Shrink Grout. Grout shall be Sika 212, Euco N-S, Five Star, or approved equal nonmetallic cementitious commercial grout exhibiting zero shrinkage per ASTM C827. Grout shall not be amended with cement or sand and shall not be reconditioned with



water after initial mixing. Nonshrink grout shall be placed and packed only with the use of an approved commercial bonding agent. Unused grout shall be discarded after 20 minutes.

- 5.5 Manholes shall conform to ASTM C478-03 with yard permeability tests passing ASTM C497-03 prior to delivery. Manhole steps shall be plastic with ½" grade 60 steel reinforcing bar encapsulated with injection molded copolymer polypropylene with serrated surfaces. Preformed gaskets shall be Ram-Nek, Kent-Seal No. 2, or approved equal.
- 5.6 Trench Backfill Materials
- 5.6.1 Foundation Stabilization: 3"-0 to 6"-0 aggregate base rock meeting OSS Sections 00641 and 02630. Required when native trench foundation material contains groundwater, or is unsuitable to provide a firm foundation in the opinion of the City Engineer or City representative.
- 5.6.2 Pipe Bedding and Zone: ¾"-0 dense-graded aggregate, uniformly graded from coarse to fine and meeting OSS Section 02630.10.
- 5.6.3 Class A Backfill: Native or common excavated material, free from organic or other deleterious material, free from rock larger than 3-inches, and which meets the characteristics required for the specific surface loading or other criteria of the backfill zone in the opinion of the City Engineer or City representative. If stockpiled material becomes saturated or unsuitable, Class B, C or D Backfill shall be substituted.
- 5.6.4 Class B Backfill: ¾"-0 dense graded aggregate, uniformly graded from coarse to fine and meeting OSS Section 02630.10.
- 5.6.5 Class C Backfill: Clean sand with no particles larger than ¼-inch.
- 5.6.6 Class D Backfill: Pit run or bar run material, well graded from coarse to fine, with maximum aggregate size of 3 inches.
- 5.6.7 Class E Backfill (CLSM): Controlled Low-Strength Material (cement slurry) conforming to OSS Section 00442.
- 5.6.8 Compaction: Material (except Class E Backfill) shall be compacted in multiple lifts (6-inch maximum lift) to obtain 95% of the maximum dry density as determined by AASHTO T-99.
- 5.6.9 All Backfill within public right-of-ways or within 5 feet of a traveled surface shall be Class B Backfill, except where Class E Backfill is required under pavements by City or State requirements.
- 5.7 Sewer Pipe Materials
- 5.7.1 PVC gravity pipe, 4- through 15-inch nominal diameter shall be rubber gasketed, SDR35 minimum, conforming to all requirements of ASTM D3034 in

accordance with ASTM D1784. Pipe shall incorporate integral wall-thickened bells with bonded-in elastomeric gaskets meeting ASTM F477.

- 5.7.2 PVC gravity pipe, 18- through 27-inch nominal diameter shall be rubber gasketed, SDR35 minimum, conforming to all requirements of ASTM F679 in accordance with ASTM D1784. Pipe shall incorporate integral wall-thickened bells with bonded-in elastomeric gaskets meeting ASTM F477. Larger diameter pipes to be approved by the City Engineer or City representative on a case by case basis.
- 5.7.3 Force Mains. PVC pipe, 4- through 12-inch nominal diameter shall be rigid PVC made from class 12454-A or B compounds as defined in ASTM D1784. Pipe shall be Class 150 meeting DR18, minimum, conforming to all requirements of AWWA C900. Pipe shall incorporate integral wall-thickened bells with bonded-in elastomeric gaskets meeting ASTM F477.
- 5.7.4 Ductile iron pipe shall be Class 50 minimum thickness (Class 51 for 14-inch and larger) manufactured in accordance with ANSI/AWWA C151/A21.51 under method of design outlined in ANSI/AWWA C150/A21.50. Pipe interior shall have a lining suitable for septic sewer service such as Protecto 401 or similar approved lining. External pipe coating shall be an asphaltic coating in accordance with ANSI/AWWA C151/A21.51. Use only where approved by City.
- 5.7.5 Small diameter pipe for individual grinder pumps shall be Class 200 / SDR 21 PVC pipe meeting ASTM D2241, or PE3408 HDPE / SDR 7, IPS size as required. Proper pack joints and stiffeners required with HDPE pipe.
- 5.8 Fittings
  - 5.8.1 PVC fittings for gravity pipe shall be rubber gasketed sewer fittings meeting ASTM D3034, SDR 35, ASTM F477, and ASTM D3212.
  - 5.8.2 Joints for ductile iron pipe and C900 pipe shall be ductile iron mechanical joint (force mains) or push-on type (gravity). Fittings shall conform to ANSI/AWWA C110/A21.10 Standard (full body) or ANSI/AWWA C153/A21.53 (compact), with 250 psi minimum working pressure rating. All gray and ductile iron fittings shall be lined with a coating suitable for septic sewer service such as Protecto 401 or as approved. Exterior of fittings shall have an asphaltic coating in accordance with ANSI/AWWA C110/A21.10. Joints and gaskets for fittings shall conform to ANSI/AWWA C111/A21.11 Standard.
  - 5.8.3 Joint restrainers for MJ fittings shall be Megalug by EBAA Iron, or approved equal, specifically designed for the type of pipe material used.
  - 5.8.4 Service laterals shall be made by the use of new PVC in-line tees with manufactured bends (Wyes) to the main.
    - 5.8.4.1 Connections to the pipe shall be made with GPK in-line fittings, GPK saddle wyes or "Inserta-Tee" as manufactured by Fowler Manufacturing

or approved equal. Installation shall be as manufactures recommendations. PVC Tee Saddle manufactured in accordance with ASTM D3034 with neoprene rubber gasket seal and ASTM F477 lateral pipe seal gasket. Stainless steel bands, series 300, 9/16-inch wide minimum.

5.8.4.2 Cast ductile iron saddle with virgin SBR rubber gasket and adjustable 3½-inch wide stainless steel strap. Romac Style "CB" or approved equal. Not allowed with plastic sewer pipe except C900.

5.8.4.3 Where existing pipe is damaged, interfering joints exist, or other conditions necessitate, or when directed by the City, cut in a regular pipe wye with pipe spools and Fernco type couplings.

5.8.4.4 All taps or connections to the existing main shall be made in the presence of the City Engineer or City representative.

5.8.5 Couplings for gravity sewer piping shall be flexible rubber type with stainless steel bands. Fernco or approved equal. Use only where approved. Rotate so that 'size' and 'type' information is turned upward to allow for inspection.

5.8.6 Manhole Connections

5.8.6.1 Connections to precast manhole sections shall be accurately core-drilled and shall utilize a properly sized flexible rubber boot providing a watertight seal. Adapter shall be factory tested for watertightness up to 10.8 psi. Kor-N-Seal as manufactured by NPC, Inc. or approved equal.

5.8.6.2 Connections to cast-in-place concrete shall be made with a rubber waterstop grouting ring. Ring shall clamp to pipe with stainless steel clamp and have waterstop ribs. Waterstop Grouting Ring by Press-Seal Gasket Corp., or approved equal.

5.9 Manhole Frames and Covers. Casting shall be tough, close-grained gray iron, smooth and clean, free from blisters, blowholes and all defects and conforming to ASTM A48, Class 30. All bearing surfaces shall be planed, ground or machined to ensure flat, true surfaces. Watertight frames and covers shall be installed at all locations subject to flooding or ponding. Tamperproof frames and covers required in off-street areas and easements. Cap screws for bolt-down covers shall be stainless steel with 60,000 psi minimum tensile strength conforming to ASTM A453.

5.10 Cleanouts. Cleanouts shall be constructed of the same PVC material as used to construct the mainline collection system piping. Cleanout size, fittings, and cleanout covers shall be as shown in the City's standard detail drawings. Cleanouts shall not be installed in mainline or substituted for manholes.

**Section 6 – Sanitary Sewer Pipe Installation**

- 6.1 Prepare trench in accordance with the standard detail in a safe manner. Place and compact foundation stabilization materials as required. Notify City to allow for inspection of the trench bottom.
- 6.2 Place and compact pipe bedding material before placing pipe in the trench. Dig depression for pipe bells to provide uniform bearing along the entire pipe length. Thoroughly compact bedding material to prevent future bellies.
- 6.3 Prior to lowering pipe into the trench, the Engineer and City representative will check for damage to the pipe. The Contractor shall repair or replace, as directed, all damaged or flawed pipe prior to installation.
- 6.4 Thoroughly clean inside the pipe before laying. Prevent foreign material from entering the pipe while it is being placed in the trench. Remove all foreign material from the inside of the pipe and joint before the next pipe is placed. Keep debris, tools, rags or other materials out of the pipe at all times. When pipe laying is not in progress, cover the exposed end of the pipe using a watertight expanding plug, or by other approved means to prevent entry of trench water or other foreign materials into the pipe.
- 6.5 Lay pipe with bell ends facing the direction of laying. For lines on an appreciable slope, face bells up-grade unless otherwise directed by the City. Thoroughly clean the ends of the pipe to remove all foreign matter from the pipe joint. Lubricate the bell and spigot ends with approved pipe lubricant, as recommended by the manufacturer.
- 6.6 PVC pipe shall be installed and handled in accordance with the Uni-Bell Plastic Pipe Association standards UNI-B-3, these specifications and the manufacturer's installation guide. The Contractor shall have on site all proper tools and equipment to properly and safely install the pipe.
- 6.7 Place materials in the pipe zone in layers not greater than 6 inches thick and in a manner that equalizes the pressure on the pipe and minimizes stress. As required under the haunches of pipe and areas not accessible to mechanical tampers or to testing, compact with hand methods to ensure thorough contact between the material and the pipe. Before placing the pipe zone material, condition, aerate, or wet the material so that the moisture content of each layer is within minus 4% to plus 2% of optimum moisture content.
- 6.8 Provide proper Backfill Class material as required. Backfill the trench above the pipe zone in successive lifts. Do not allow the backfill to free-fall into the trench until at least 3 feet of cover is provided over the top of the pipe. Modify the compaction as necessary to protect the pipe. Compact each lift to not less than 95% of the maximum density.
- 6.9 If the specified compaction is not obtained, contractor shall remove material, modify compaction procedures, and/or reduce the thickness of lifts as required. Do not proceed with additional excavation or pipe laying until the backfill can be compacted to the satisfaction of the City.
- 6.10 CLSM. When CLSM Backfill is required, backfill above pipe zone with CLSM material. If the CLSM is to be used as a temporary surfacing, backfill to top of the trench and

strike off to provide a smooth surface. If CLSM is not to be used as a temporary surface, backfill to bottom of the proposed resurfacing. Use steel plates to protect the CLSM from traffic a minimum of 24 hours.

- 6.11 Provide concrete thrust blocking at all bends, valves, tees and other fittings in accordance with the standard details, as required to prevent movement due to thrust. Mechanical joint restraints shall also be installed.
- 6.12 Where new water pipe is installed near existing or new sanitary sewer lines, all provisions of current OAR 333-61-050 (Crossings – Sanitary sewers and waterlines), regarding placement of pipe near, under, or over sanitary sewer lines shall be followed.
- 6.13 Restore all surfaces after backfill is complete. Base rock, asphalt paving and concrete paving methods and materials shall conform to Oregon Standard Specifications as approved by the City and/or ODOT, as appropriate.
- 6.14 Pressure pipe shall be installed and tested in accordance with City of Cave Junction Standards contained in this Manual.
- 6.15 Tolerance. For gravity pipelines, vertical deviation from true grade shall not exceed 0.02 feet (0.24 inch). Horizontal tolerance for deviation from line shall be 0.03125 feet (3/8 inch). Depressions or bellies which create the potential for solids deposition are not allowed.
- 6.16 Testing. After installation, sewer system shall be tested for exfiltration allowances and defects according to the following Sections. All lines shall also be video inspected in the presence of City representative at Owner/Developers expense, for bellies and defects. Prior to acceptance all pipe sections including laterals and all manholes shall pass the acceptance criteria. All items not passing tests shall be repaired or replaced as required.

#### **Section 7 – Low-Pressure Air Testing of Gravity Sewers (per UNI-B-6-98 / ASTM F1417)**

- 7.1 The Contractor shall furnish all equipment, materials and personnel required for properly conducting all required low-pressure air testing under observation of the Engineer. Pressure gauge shall have 0.10 psi increments and an accuracy of 0.0625-psi. Testing equipment must include a pressure relief device designed to relieve pressure at a maximum of 9 psi and must allow continuous monitoring of the test pressure to avoid excessive pressure. All air used shall pass through a single control valve. Only qualified personnel shall be permitted to conduct the test. The Time Pressure Drop Method shall be used.
- 7.2 Testing shall be done in the presence of a City representative. Testing shall be conducted after backfilling and compaction has been completed to finish grade. Notify City at least 2 working days in advance.
- 7.3 Initial Test – A test shall be conducted on the first section of pipe laid by each crew to establish that the pipeline installation is capable of preventing excessive infiltration. The section of pipeline tested shall be at least 300 feet in length. If the test indicates exfiltration exceeding the amount hereinafter specified, all defective materials and/or workmanship shall be corrected and the test rerun until leakage is within the specified limits.

- 7.4 If, in the opinion of the City, the water tightness of the pipe is in question during installation, the City may require the Contractor to test the pipe sections in question. Such testing shall not be considered adequate for final pipe testing, performed after the pipe is installed, backfilled, compacted and cleaned. Thereafter all sewer pipe shall be tested as provided herein.
- 7.5 The Contractor may desire to make air tests prior to complete backfilling, for his own purposes; however, acceptance air test shall be made only after installation of all laterals and backfilling has been completed and compacted. It is recommended that testing be completed and accepted prior to paving in the event that some piping may require excavation for repair of deficiencies.
- 7.6 It is extremely important that all plugs, including end of service laterals, be installed and braced such that blowouts are prevented (ex. 250 lbs force is exerted on an 8" plug at 5 psig). Exercise care to prevent excessive pressures. Keep workers out of manholes until pressure is released.
- 7.7 Testing Procedure
- 7.7.1 Immediately following pipe cleaning, the pipe installation shall be tested with low pressure air. Each pipe section between manholes shall be tested. Service laterals from the main to the property line shall be included in the test.
- 7.7.2 Check the average height of ground water over the pipe invert. The test pressure required below shall be increased 0.433 psi for each foot of average water depth over the pipe (ex. If groundwater is 2.8 feet above pipe invert, add 1.2 psig to test pressures). Method used to determine groundwater depth shall be acceptable to the City.
- 7.7.3 Air shall be slowly supplied to the plugged pipe until internal air pressure reaches 4.0 psi greater than the average back pressure of any ground water that may submerge the pipe. Do not exceed a total pressure of 9.0 psig.
- 7.7.4 After the internal test pressure is reached, at least two minutes shall be allowed for the air temperature to stabilize. After the stabilization period, disconnect the air supply.
- 7.7.5 The continuous monitoring pressure gauge shall then be observed while the pressure is decreased to no less than 3.5 psig (greater than average backpressure of any groundwater over the pipe). At a reading of 3.5 psig, or any convenient pressure between 3.5 psig and 4.0 psig (above groundwater pressure), timing shall commence with an accurate stopwatch.
- 7.7.6 Acceptance - The tested section shall be considered acceptable if the required testing time has elapsed before a 1.0 psig pressure drop has occurred. If the pressure drops 1.0 psig before the minimum length of time has elapsed, the air loss rate is considered excessive and the section of pipe has failed the test.

- 7.7.7 Acceptance criteria is based on an allowable air loss of  $Q=0.0015$  cfm per  $\text{ft}^2$  of internal pipe surface area less than  $625 \text{ ft}^2$ . This results in a total allowable loss of  $625Q = 0.94$  cfm. The shortest time (T), in seconds, allowed for the air pressure to drop 1.0 psig is calculated with the following formula:

$$T = 0.085 (DK/0.0015)$$

$K = 0.000419DL$  but not less than 1.0, D = pipe I.D. in inches, and L = length of pipe tested in feet.

- 7.7.8 Contractor shall record and document the testing procedure and results during the testing process. The UNI-Bell "Air Test Data Sheet" or similar approved equal shall be used and submitted to the Engineer. Record the diameter (in), length (ft), start and end manhole numbers, time, date, pressure drop, and groundwater level on inspection form. Submit to City.

#### Minimum Specified Time Required for 1.0 PSIG Pressure Drop

Pipe ø (in)	T <sub>min</sub> (min:sec)	L for T <sub>min</sub> (ft)	T for longer L (sec)	Specification Time for Length (L) Shown (min:sec)								
				100 ft	150 ft	200 ft	250 ft	300 ft	350 ft	400 ft	450 ft	
4	3:46	597	.380L	3:46	3:46	3:46	3:46	3:46	3:46	3:46	3:46	3:46
6	5:40	398	.854L	5:40	5:40	5:40	5:40	5:40	5:40	5:40	5:42	6:24
8	7:34	298	1.520L	7:34	7:34	7:34	7:34	7:36	8:52	10:08	11:24	
10	9:26	239	2.374L	9:26	9:26	9:26	9:53	11:52	13:51	15:49	17:48	
12	11:20	199	3.418L	11:20	11:20	11:24	14:15	17:05	19:56	22:47	25:38	
15	14:10	159	5.342L	14:10	14:10	17:48	22:15	26:42	31:09	35:36	40:04	
18	17:00	133	7.692L	17:00	19:13	25:38	32:03	38:27	44:52	51:16	57:41	
21	19:50	114	10.470L	19:50	26:10	34:54	43:37	52:21	61:00	69:48	78:31	
24	22:40	99	13.674L	22:47	34:11	45:34	56:58	68:22	79:46	91:10	102:33	
27	25:30	88	17.306L	28:51	43:16	57:41	72:07	86:32	100:57	115:22	129:48	
30	28:20	80	21.366L	35:37	53:25	71:13	89:02	106:50	124:38	142:26	160:15	

*If no pressure drop (0 psig) has occurred after 1 hour, test may conclude and section passes*

- 7.7.9 Service laterals shall be included in test. However the length of service laterals may be ignored and the length of main line only used in the above table. If desired, length of service laterals included in test section may be included in the calculation by following the method outlined in UNI-B-6-98 Section 9.4.

### Section 8 – Hydrostatic Testing of Pipe

- 8.1 Contractor shall provide all hose, temporary piping, approved pipe plugs, tank trucks, and other equipment, labor and material required to make the hydrostatic tests, and shall pay for the water used, unless otherwise approved by the City. Testing of the pipe shall be conducted in the presence of a City representative. Testing shall be conducted after backfilling and compaction has been completed to finish grade. Notify City at least 2 working days in advance.
- 8.2 Prior to making exfiltration leakage tests, contractor may fill the pipe with clear water to permit normal absorption into the pipe walls; provided however, that after filling the

pipe, leakage testing shall be completed within twenty-four (24) hours after filling. When under test, allowable leakage shall comply with the following requirements:

Leakage shall not exceed 0.04 gallons per hour per inch diameter per one hundred (100) feet of sanitary sewer pipe, with a minimum test pressure of six (6) feet of water column above the highest section of pipe (including service laterals), or above the active ground water table, whichever is higher as determined by the City. The length of pipe tested shall be limited so that the pressure on the invert of the lower end of the section tested shall not exceed 28 feet of water column, and in no case shall be greater than 500 feet. All service connection footage shall be taken into account in computing allowable leakage. Test duration shall be at least 2 hours. Methods of imposing the water column and measuring the water loss shall be acceptable to the City.

### **Section 9 – Vacuum Testing of Manholes (per ASTM C1244)**

- 9.1 Precast concrete manholes shall be tested in accordance with the following procedure. Manhole installations which fail the testing shall be repaired or replaced until passing results are obtained. If flexible joint sealant is pulled out during testing, it shall be repaired.
- 9.2 Testing shall be done in the presence of a City representative. Notify City at least 2 working days in advance. Use Report Form approved by City.
- 9.3 All manholes shall be tested for acceptance after the trench has been backfilled, compaction requirements have been met, road base rock has been installed, paving is complete, and concrete manhole collars have been installed. If manhole has passed test and the castings have later been disturbed, manhole shall be re-tested.
- 9.4 Thoroughly clean all manholes prior to testing. Remove all debris and do not allow foreign material to enter downstream piping.
- 9.5 Contractor shall provide all necessary equipment and personnel to conduct the testing, including vacuum equipment and indicating devices.
- 9.6 Procedure
  - 9.6.1 Plug all pipes entering manhole. Secure all plugs to prevent movement while vacuum is being drawn.
  - 9.6.2 Testing shall include the joint between the manhole cone or riser ring(s) and the manhole cover frame.
  - 9.6.3 Installation and operation of vacuum equipment and indicating devices shall be in accordance with the manufacturer's specifications and instructions.
  - 9.6.4 Withdraw air from the manhole until a measured vacuum of 10-inches of mercury (10" Hg = 4.9 psi) is established in the manhole interior.



- 9.6.5 Record the time it takes for the vacuum to drop to 9-inches of mercury (9" Hg = 4.4 psi). Acceptance standards are based on this 1-inch of mercury change in negative pressure. Time measured for the 1" Hg (1" Hg = 0.5 psi) pressure change shall be equal to or greater than the values in the following table:

Manhole Depth (ft)	Manhole Diameter (in)				
	42"	48"	54"	60"	72"
8' or less	17	20	23	26	33
10	21	25	29	33	41
12	25	30	35	39	49
14	30	35	41	46	57
16	34	40	46	52	67
18	38	45	52	59	73
20	42	50	53	65	81
22	46	55	64	72	89

- 9.6.6 Hydrostatic testing of manholes may be allowed. Test shall be in accordance with ASTM C497 as modified here. Test will consist of plugging all inlets and outlets and filling the manhole with water to the rim. Leakage in each manhole shall not exceed 0.2 gallons per hour per foot of head above the invert. Leakage will be determined by refilling to the rim using a calibrated or known volume container. Testing duration shall be at least 2 hours. Testing results shall be recorded on a form approved by the City.

### **Section 10 – Deflection Testing for Flexible Pipe**

- 10.1 In addition to air or hydrostatic testing, the contractor shall conduct deflection tests of sanitary sewers constructed of flexible pipe. Testing will consist of pulling an approved mandrel through the completed pipeline after backfill and compaction to finish grade is complete. Testing shall be conducted in the presence of a City representative.
- 10.2 Diameter of the mandrel shall be at least 95% of the pipe internal diameter. Mandrel shall have at least 6 vanes.
- 10.3 Testing shall be done from manhole to manhole. Pipe shall be thoroughly cleaned and flushed prior to pulling the mandrel. Mandrel shall pass smoothly through the pipe without excessive effort.
- 10.4 Testing shall be conducted only after at least 30 days have elapsed after backfill and compaction was completed. May be conducted concurrently with video inspection.

### **Section 11 – Video Inspection of Gravity Systems**

- 11.1 All gravity sewer lines constructed as part of the project shall be televised and taped at the end of construction prior to acceptance. Taping shall be conducted after all backfill and compaction, but prior to final surface restoration. All pipes shall be thoroughly flushed by the Contractor immediately prior to the video inspection. The video shall be

recorded in color on VHS or DVD format. Sufficient light shall be provided to show detail. Camera speed shall not exceed 3 feet per second. Camera shall have a swivel (pan and tilt) head capable of looking up each service connection. A copy of the video tape and a written TV Inspection Report shall be furnished to the City. Any sections of sewer pipe not meeting specifications or exhibiting defects shall, at the Contractor's expense, be corrected to meet specification. Repaired sections shall be re-televised. All repairs must be completed before acceptance of the project.

- 11.2 The sanitary sewer lines constructed as part of the project will also be video inspected near the end of the one-year or two-year warranty period as appropriate to determine if any defects exist in the system. The warranty video inspection will be conducted during a season of high groundwater as close to the end of the warranty period as possible. The warranty period will continue to be in effect, regardless of duration, until all video recordings are received and approved. All defects in the system will be corrected at the developer's or contractor's expense.
- 11.3 Video inspection and taping costs will be borne by the contractor or developer unless otherwise approved.
- 11.4 All video inspection and tapping shall be conducted in the presence of a City representative.

## Guidelines for Development Sanitary Sewer Designs Standards Manual:

### Testing and Data Sheets

Pipe Air Test Data Sheet  
Gravity Pipe Hydrostatic Test  
Manhole Vacuum Test  
Manhole Hydrostatic Test





**Vacuum Testing of Manholes (per ASTM C1244)**

- A. Precast concrete manholes shall be tested in accordance with the following procedure. Manhole installations which fail the testing shall be repaired or replaced until passing results are obtained. If flexible joint sealant is pulled out during testing, it shall be repaired.
- B. Testing shall be done in the presence of a City representative. Notify City at least 48 hours in advance. Use Report Form approved by City.
- C. All manholes shall be tested for acceptance after the trench has been backfilled, compaction requirements have been met, road base rock has been installed, paving is complete, and concrete manhole collars have been installed. If manhole has passed test and the castings have later been disturbed, manhole shall be re-tested.
- D. Thoroughly clean all manholes prior to testing. Remove all debris and do not allow foreign material to enter downstream piping.
- E. Contractor shall provide all necessary equipment and personnel to conduct the testing, including vacuum equipment and indicating devices.
- F. Procedure
  - 1. Plug all pipes entering manhole. Secure all plugs to prevent movement while vacuum is being drawn.
  - 2. Testing shall include the joint between the manhole cone or riser ring(s) and the manhole cover frame.
  - 3. Installation and operation of vacuum equipment and indicating devices shall be in accordance with the manufacturer’s specifications and instructions.
  - 4. Withdraw air from the manhole until a measured vacuum of 10-inches of mercury (10" Hg) is established in the manhole interior.
  - 5. Record the time it takes for the vacuum to drop to 9-inches of mercury (9" Hg). Acceptance standards are based on this 1-inch of mercury change in negative pressure. Time measured for the 1" Hg pressure change shall be equal to or greater than the values in the following table:

**Vacuum Testing Requirements (minimum test times, seconds)**

Manhole Depth (ft)	Manhole Diameter (in)				
	42"	48"	54"	60"	72"
8' or less	17	20	23	26	33
10	21	25	29	33	41
12	25	30	35	39	49
14	30	35	41	46	57
16	34	40	46	52	67
18	38	45	52	59	73
20	42	50	53	65	81
22	46	55	64	72	89



## Testing Procedure

- 1) Immediately following pipe cleaning, the pipe installation shall be tested with low pressure air. Each pipe section between manholes shall be tested. Service laterals from the main to the property line shall be included in the test.
- 2) Check the average height of ground water over the pipe invert. The test pressure required below shall be increased 0.433 psi for each foot of average water depth over the pipe (ex. If groundwater is 2.8 feet above pipe invert, add 1.2 psig to test pressures). Method used to determine groundwater depth shall be acceptable to the City.
- 3) Air shall be slowly supplied to the plugged pipe until internal air pressure reaches 4.0 psi greater than the average back pressure of any ground water that may submerge the pipe. Do not exceed a total pressure of 9.0 psig.
- 4) After the internal test pressure is reached, at least two minutes shall be allowed for the air temperature to stabilize. After the stabilization period, disconnect the air supply.
- 5) The continuous monitoring pressure gauge shall then be observed while the pressure is decreased to no less than 3.5 psig (greater than average backpressure of any groundwater over the pipe). At a reading of 3.5 psig, or any convenient pressure between 3.5 psig and 4.0 psig (above groundwater pressure), timing shall commence with an accurate stop watch.
- 6) Acceptance - The tested section shall be considered acceptable if the required testing time has elapsed before a 1.0 psig pressure drop has occurred. If the pressure drops 1.0 psig before the minimum length of time has elapsed, the air loss rate is considered excessive and the section of pipe has failed the test.
- 7) Acceptance criteria is based on an allowable air loss of  $Q=0.0015$  cfm per  $ft^2$  of internal pipe surface area less than  $625 ft^2$ . This results in a total allowable loss of  $625Q = 0.94$  cfm. The shortest time (T), in seconds, allowed for the air pressure to drop 1.0 psig is calculated with the following formula:

$T = 0.085 (DK/0.0015)$ ;  $K = 0.000419DL$  but not less than 1.0,  $D =$  pipe I.D. in inches, and  $L =$  length of pipe tested in feet.

- 8) Contractor shall record and document the testing procedure and results during the testing process. The UNI-Bell "Air Test Data Sheet" or similar approved equal shall be used and submitted to the Engineer. Record the diameter (in), length (ft), start and end manhole numbers, time, date, pressure drop, and groundwater level on inspection form. Submit to City.

### Minimum Specified Time Required for 1.0 PSIG Pressure Drop

Pipe $\varnothing$ (in)	$T_{min}$ (min:sec)	L for $T_{min}$ (ft)	T for longer L (sec)	Specification Time for Length (L) Shown (min:sec)							
				100 ft	150 ft	200 ft	250 ft	300 ft	350 ft	400 ft	450 ft
4	3:46	597	.380L	3:46	3:46	3:46	3:46	3:46	3:46	3:46	3:46
6	5:40	398	.854L	5:40	5:40	5:40	5:40	5:40	5:40	5:42	6:24
8	7:34	298	1.520L	7:34	7:34	7:34	7:34	7:36	8:52	10:08	11:24
10	9:26	239	2.374L	9:26	9:26	9:26	9:53	11:52	13:51	15:49	17:48
12	11:20	199	3.418L	11:20	11:20	11:24	14:15	17:05	19:56	22:47	25:38
15	14:10	159	5.342L	14:10	14:10	17:48	22:15	26:42	31:09	35:36	40:04
18	17:00	133	7.692L	17:00	19:13	25:38	32:03	38:27	44:52	51:16	57:41
21	19:50	114	10.470L	19:50	26:10	34:54	43:37	52:21	61:00	69:48	78:31
24	22:40	99	13.674L	22:47	34:11	45:34	56:58	68:22	79:46	91:10	102:33
27	25:30	88	17.306L	28:51	43:16	57:41	72:07	86:32	100:57	115:22	129:48
30	28:20	80	21.366L	35:37	53:25	71:13	89:02	106:50	124:38	142:26	160:15

*If no pressure drop (0 psig) has occurred after 1 hour, test may conclude and section passes*

- 9) Service laterals shall be included in test however the length of service laterals may be ignored and the length of main line only used in the above table. If desired, length of service laterals included in test section may be included in the calculation by following the method outlined in UNI-B-6-98 Section 9.4.





## SEWER SYSTEM

### STANDARD DETAIL DRAWINGS INDEX

- S-050: STANDARD UTILITY LOCATIONS
- S-100: TYPICAL SEWER TRENCH DETAIL
- S-105: STREET CUT STANDARD DETAIL
- S-150: PIPE ANCHOR / TRENCH CUT-OFF WALL DETAIL
- S-200: STANDARD MANHOLE
- S-205: FLAT-TOP MANHOLE
- S-210: MANHOLE BASE STANDARD DETAILS
- S-220: STANDARD INSIDE DROP MANHOLE
- S-225: STANDARD OUTSIDE DROP MANHOLE
- S-250: MANHOLE COVER AND FRAME DETAILS
- S-260: MANHOLE FRAME GRADE ADJUSTMENT
- S-300: STANDARD SERVICE CONNECTION AND LATERAL
- S-400: TYPICAL PIPE CASING DETAIL



**City of Cave Junction**  
222 W. Lister Street  
Josephine, Oregon 97523  
(541) 592-2156

**STANDARD DETAIL  
DRAWING INDEX**

DETAIL NO.

**S-010**

SEE DWG. T-050 FOR STANDARD STREET WIDTHS AND SECTIONS

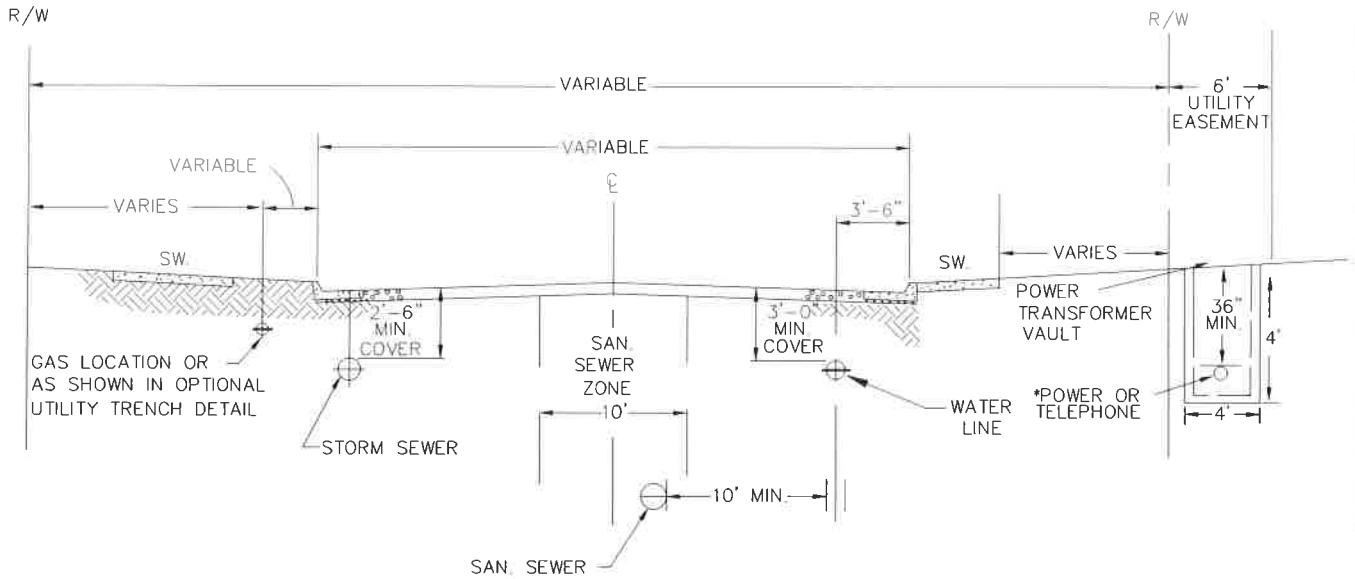

NOTES:

1. WATER LOCATED 3'-6" INSIDE FROM FACE OF CURB OR AS OTHERWISE DIRECTED.
2. 10' HORIZONTAL SEPARATION BETWEEN WATER AND SEWER WHERE POSSIBLE. COMPLY WITH SEPARATION REQUIREMENTS OF OAR 333-061-050.
3. WATER DISTRIBUTION MAINS SHALL HAVE 36" MINIMUM COVER OR AS OTHERWISE DIRECTED.
4. SEWER MAINS SHALL HAVE 5.25' (63") MINIMUM COVER UNLESS OTHERWISE APPROVED TO AVOID CONFLICTS WITH WATER AND OTHER UTILITIES.
5. WATER MAINS SHALL BE LOCATED ON NORTH OR EAST SIDE OF STREET WHEN PRACTICAL.
6. WATER, SEWER, STREET AND DRAINAGE SYSTEMS ARE SUBJECT TO CITY STANDARDS.
7. MANHOLE LIDS SHALL NOT BE LOCATED DIRECTLY IN NORMAL WHEEL PATH.
8. ALL LAYOUTS AND LOCATIONS ARE SUBJECT TO CITY APPROVAL.



City of Cave Junction  
 222 W. Lister Street  
 Josephine, Oregon 97523  
 (541) 592-2156

STANDARD UTILITY  
 LOCATIONS

DETAIL NO.  
 S-050



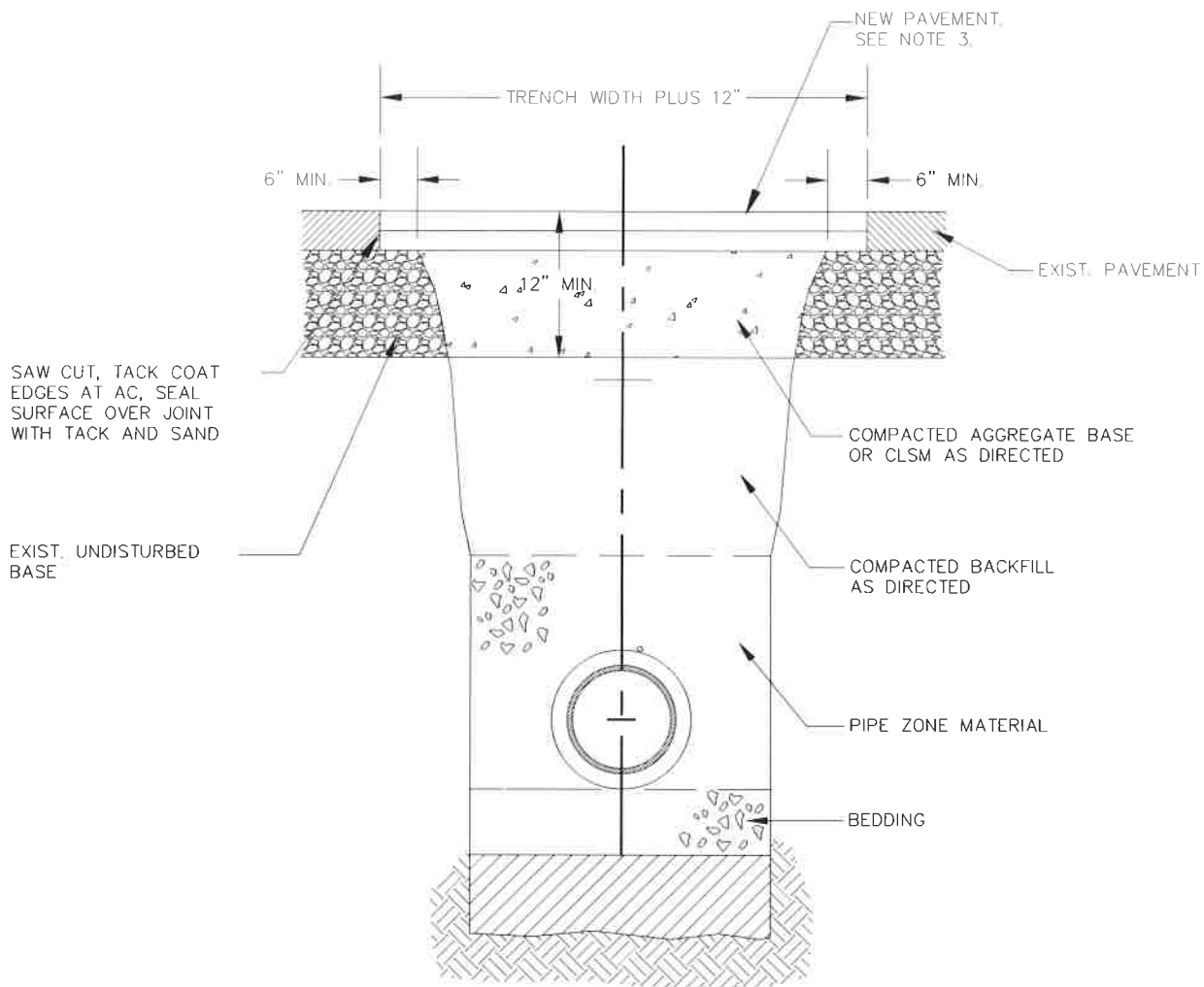

NOTES:

1. ALL EXISTING AC OR PCC PAVEMENT SHALL BE SAWCUT IMMEDIATELY PRIOR TO REPAVING.
2. CONCRETE PAVEMENT SHALL BE REPLACED WITH CONCRETE TO A MINIMUM THICKNESS OF 6 INCHES OR TO THE THICKNESS OF REMOVED CONCRETE PAVEMENT, WHICHEVER IS GREATER.
3. PLACE AC MIX TO A MINIMUM THICKNESS OF 4 INCHES OR THE THICKNESS OF REMOVED PAVEMENT, WHICHEVER IS GREATER. COMPACT AS DIRECTED. AC PAVEMENT SHALL BE PLACED IN AT LEAST TWO 2" LIFTS.
4. COMPLY WITH THE REQUIREMENTS OF THE AGENCY HAVING JURISDICTION OVER THE ROAD IN WHICH THE STREET CUT OCCURS.



City of Cave Junction  
 222 W. Lister Street  
 Josephine, Oregon 97523  
 (541) 592-2156

**STREET CUT  
 STANDARD DETAIL**

DETAIL NO.

**S-105**

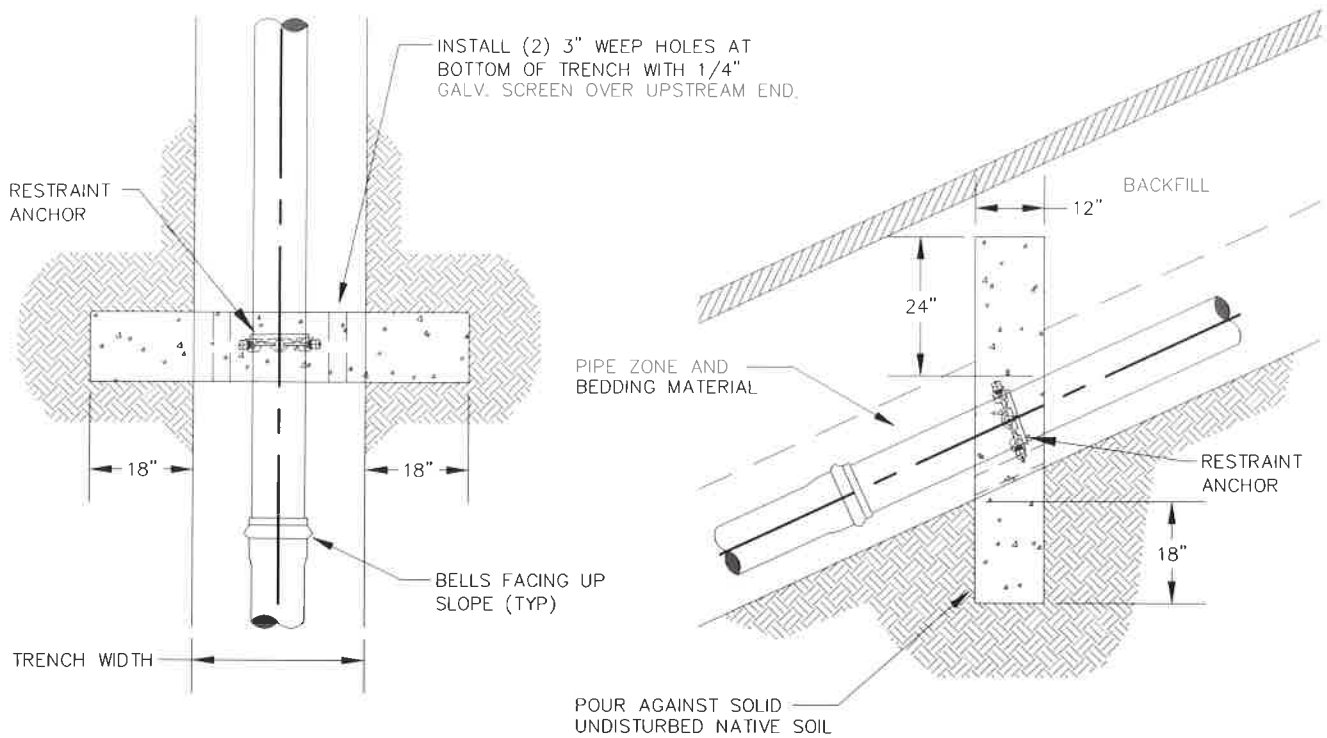

NOTES:

1. CUT-OFF WALLS REQ'D AT ALL PIPELINES WHERE SLOPE EXCEEDS 20%.
2. RESTRAINED JOINT PIPE REQUIRED AT SLOPES BETWEEN 15% AND 20%.
3. WALLS SHALL BE FORMED WITHIN TRENCH. REMOVE FORMS PRIOR TO BACKFILLING.
4. CONCRETE SHALL HAVE 3000 PSI COMPRESSIVE STRENGTH MIN. (CLASS 3000).
5. SPACING OF WALLS SHALL BE:

SLOPE	SPACING
20-34%	35 FEET
35-50%	25 FEET
51-+%	15 FEET



City of Cave Junction  
 222 W. Lister Street  
 Josephine, Oregon 97523  
 (541) 592-2156

PIPE ANCHOR / TRENCH  
 CUT-OFF WALL DETAIL

DETAIL NO.

S-150



CAST IRON (H-20 RATED)  
MANHOLE COVER AND FRAME=  
SET FRAME IN NON-SHRINK GROUT  
SEE MANHOLE COVER & FRAME  
STANDARD DETAIL (S-250)

PRECAST REINFORCED  
GRADE RINGS, 3 LAYERS MAX.  
2" MIN., 12" MAX.  
SET IN NON-SHRINK GROUT

PRECAST ECCENTRIC CONE  
SLOPE FACING DOWN GRADE  
36" TALL

KEYED JOINTS WITH PRE-  
FORMED SEAL (RAM-NEK)  
OR RUBBER RING GASKET  
BY MFR. (TYP. ALL JOINTS)  
SEAL WATERTIGHT

ALL PRECAST MANHOLE  
SECTIONS SHALL MEET  
ASTM C-478.

FLAT-TOP MANHOLE  
REQUIRED WHEN DEPTH  
FROM FINISH GRADE TO  
INVERT IS LESS THAN  
6 FEET.

INTERIOR DROPS EXCEEDING 24"  
REQUIRE DROP MANHOLE.

FINISH GRADE

26" MAX.

25"

48"

5" MIN.

12" TYP.

STEEL REINFORCED  
POLYPROPYLENE STEPS  
BY MH MFR. ALIGN  
VERTICALLY.

12" MAX.

15"-18" TYP.

SEE MANHOLE BASE  
STANDARD DETAIL (S-210)

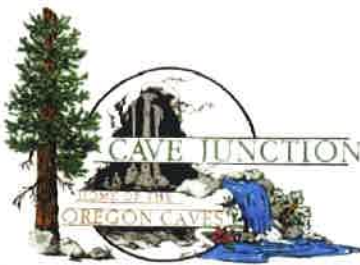

City of Cave Junction  
222 W. Lister Street  
Josephine, Oregon 97523  
(541) 592-2156

**STANDARD MANHOLE  
PIPES LESS THAN 24" DIAM.**

DETAIL NO.
<b>S-200</b>

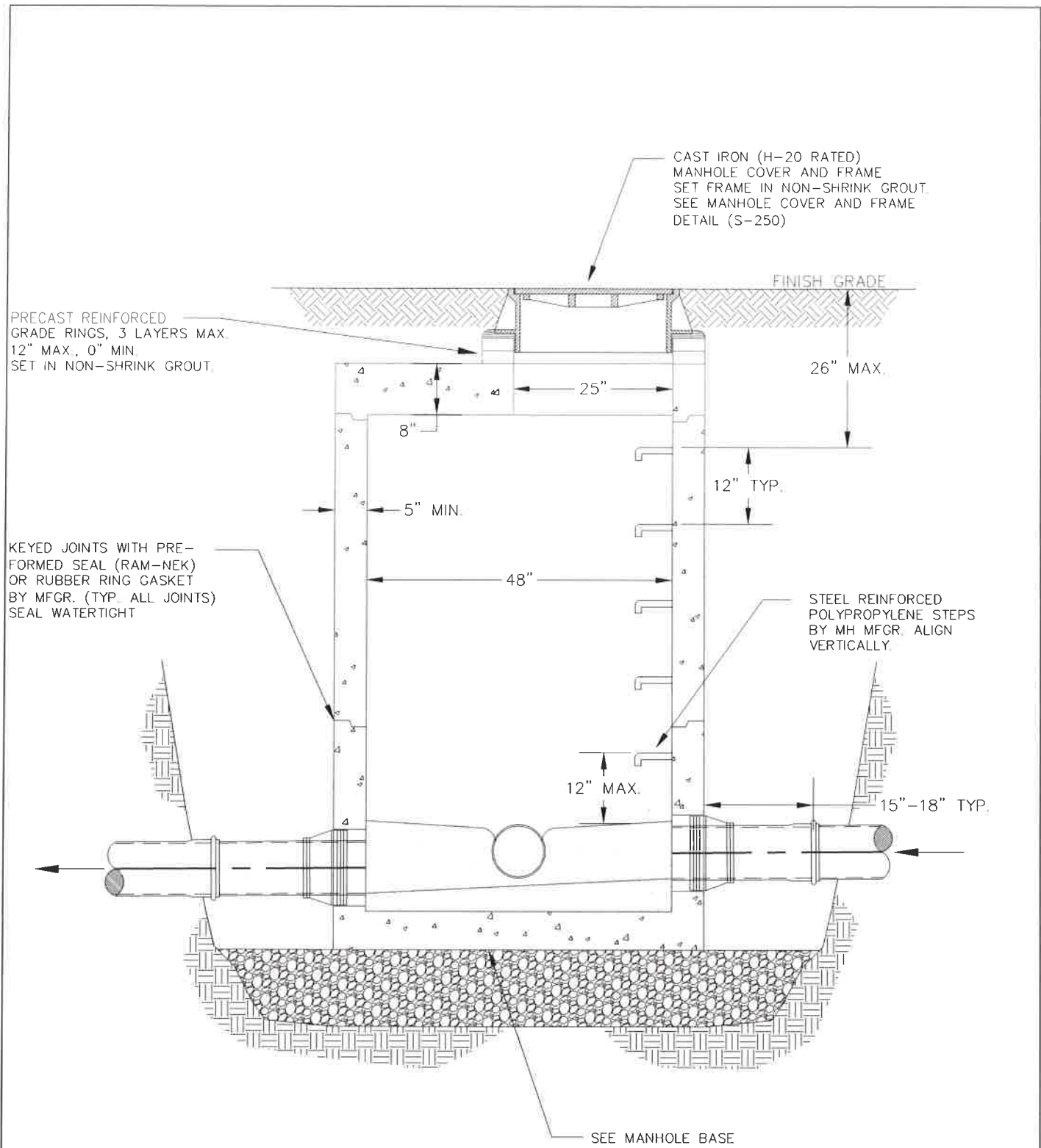

NOTE:

- 1) ALL PRECAST MANHOLE SECTIONS SHALL MEET ASTM C-478.
- 2) STANDARD MANHOLE REQUIRED WHEN DEPTH FROM FINISH GRADE TO INVERT IS 6 FEET OR MORE.

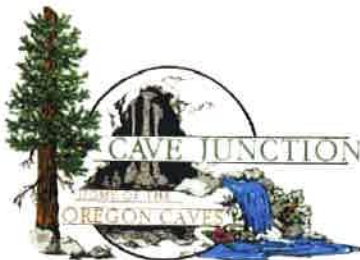

City of Cave Junction  
222 W. Lister Street  
Josephine, Oregon 97523  
(541) 592-2156

**FLAT-TOP MANHOLE  
PIPES LESS THAN 24" DIAM.**

DETAIL NO.

**S-205**



AT SPRING LINE OF PIPE  
EXTEND CHANNEL UP TO  
CROWN LINE ON 12:1  
BATTER (TYP)

BENCH SLOPE  
12:1 (TYP)

FLEXIBLE RUBBER BOOT  
KOR-N-SEAL OR EQUAL  
AS APPROVED.

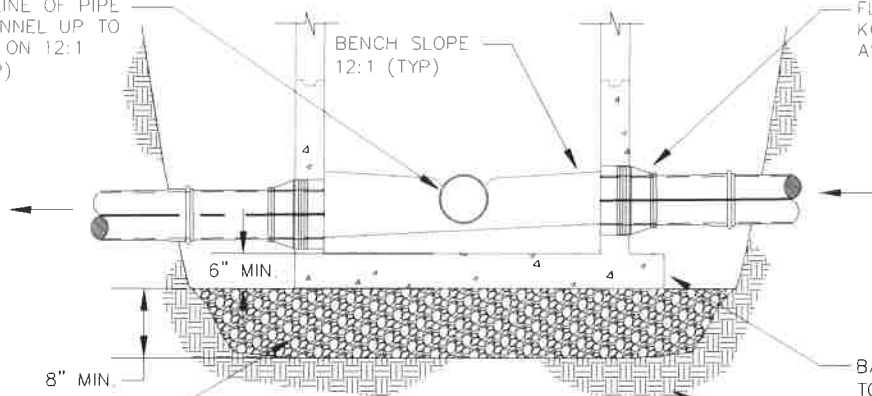

3/4"-0 CRUSHED  
ROCK BASE (TYP)

### PRECAST BASE

PRECAST BASE HEIGHT  
SUFFICIENT TO AVOID  
JOINT AT PIPE PENETRATIONS

BASE EXTENSION AS REQ'D  
TO PREVENT UPLIFT (TYP)

UNDISTURBED EARTH OR  
COMPACT SELECT MATERIAL  
AS REQ'D (95%) (TYP)

OR GREATER AS REQ'D  
TO PREVENT UPLIFT

RAM-NEK SEAL

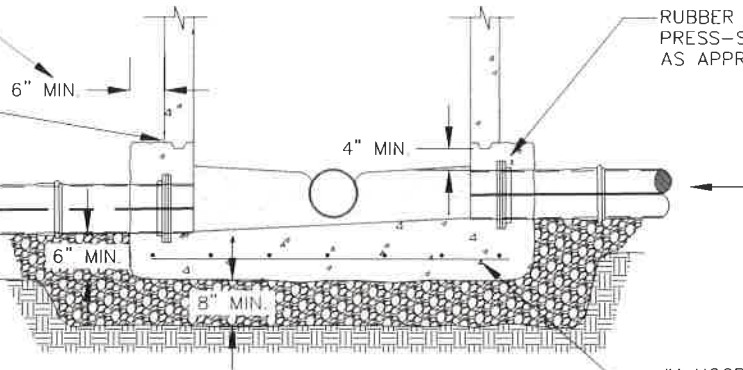

RUBBER WATERSTOP GROUT RING  
PRESS-SEAL GASKET OR EQUAL  
AS APPROVED

#4 HOOP AND #4 @ 12" E.W.  
#5 BARS WHEN DEPTH  
EXCEEDS 15'

### CAST-IN-PLACE BASE

CONTOUR TO PROVIDE  
SMOOTH CHANNELS  
SHAPE TO AVOID SOLIDS  
DEPOSITION AND DIRECT  
HEAD-ON FLOWS

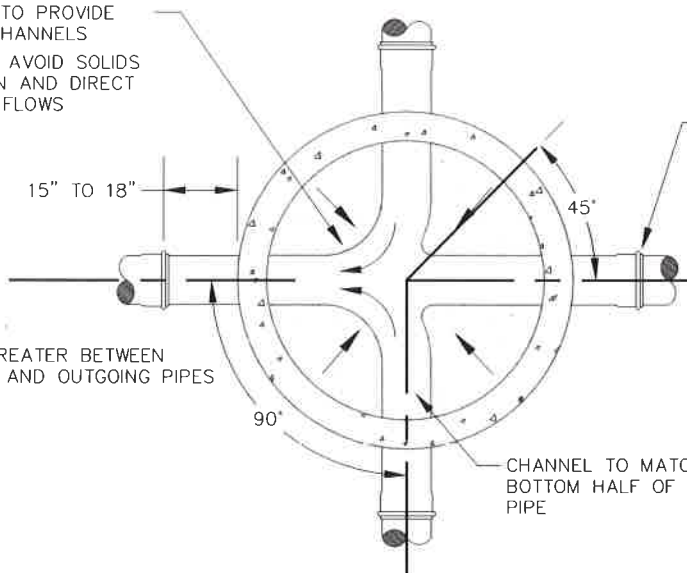

PIPE JOINT  
FLEXIBLE COUPLING  
WHERE CONNECTING  
TO EXIST. PIPE

90° OR GREATER BETWEEN  
INCOMING AND OUTGOING PIPES

PRECAST OR CAST-IN-PLACE  
BASE AT CONTRACTOR'S  
OPTION OR AS DIRECTED.

ALL FIELD PLACED CONCRETE  
SHALL BE TYPE II PCC WITH  
3000 PSI MIN. STRENGTH

MIN. 0.2 FT. INVERT DROP  
ACROSS INLET AND OUTLET  
PIPES.



City of Cave Junction  
222 W. Lister Street  
Josephine, Oregon 97523  
(541) 592-2156

## MANHOLE BASE STANDARD DETAILS

DETAIL NO.

S-210

FIBERGLASS DROP BOWL RELINER OR INTRAFLOW BY ROYAL ENVIRONMENTAL SYSTEMS OR APPROVED EQUAL. SECURE WITH SS FASTENERS.

STAINLESS STEEL STRAPS SECURED TO WALL WITH SS FASTENERS AT 4' INTERVALS (MIN. OF 2) RELINER STRAPS.

ASTM D3034 PVC SEWER PIPE (SDR 35) SIZE TO MATCH INLET SEWER

FILL ANNULAR SPACE WITH NON-SHRINK GROUT PRIOR TO SECURING BOWL

INLET SEWER

48"

EXTERNAL PIPE COUPLING (FERNCO)

DROP END CHANNEL (RELINER DROP END)

45° ELBOW WITH FORMED CONCRETE SLIDE AND CHANNEL MAY BE USED IN EXISTING MANHOLES

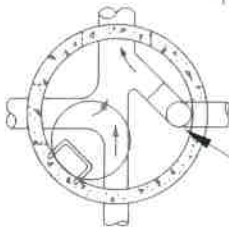

INSIDE DROP

**NOTES:**

1. DROP MANHOLES SHALL ONLY BE USED WITH PRIOR APPROVAL FROM CITY OF COOS BAY.
2. RELINER DROP BOWL, 8" OUTLET (B8) FOR 8" INLET SEWERS. B10 FOR 10" SEWERS. CONSULT CITY ENGINEER FOR LARGER SIZES.
3. EXTEND INLET SEWER PIPE 2" INTO MANHOLE. CUT "V" NOTCH IN BOTTOM OF PIPE PROTRUSION. FOLLOW RELINER INSTRUCTIONS.
4. INTRAFLOW INSIDE DROP SYSTEM ACCOMODATES 6" TO 12" SEWERS. INTRAFLOW SECTIONS SHALL BE AT LEAST 4" WIDER THAN INLET SEWER. OUTLET ELBOW TO MATCH INLET SEWER SIZE.
5. ONLY ONE DROP ASSEMBLY ALLOWED PER MANHOLE.



**City of Cave Junction**  
 222 W. Lister Street  
 Josephine, Oregon 97523  
 (541) 592-2156

**STANDARD INSIDE DROP  
 MANHOLE**

DETAIL NO.

**S-220**

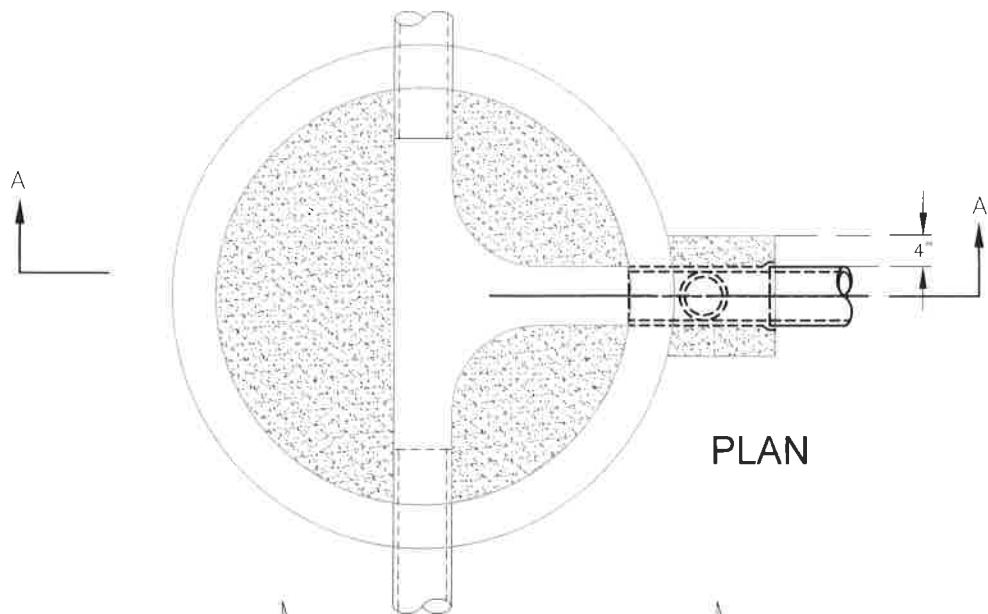

PLAN

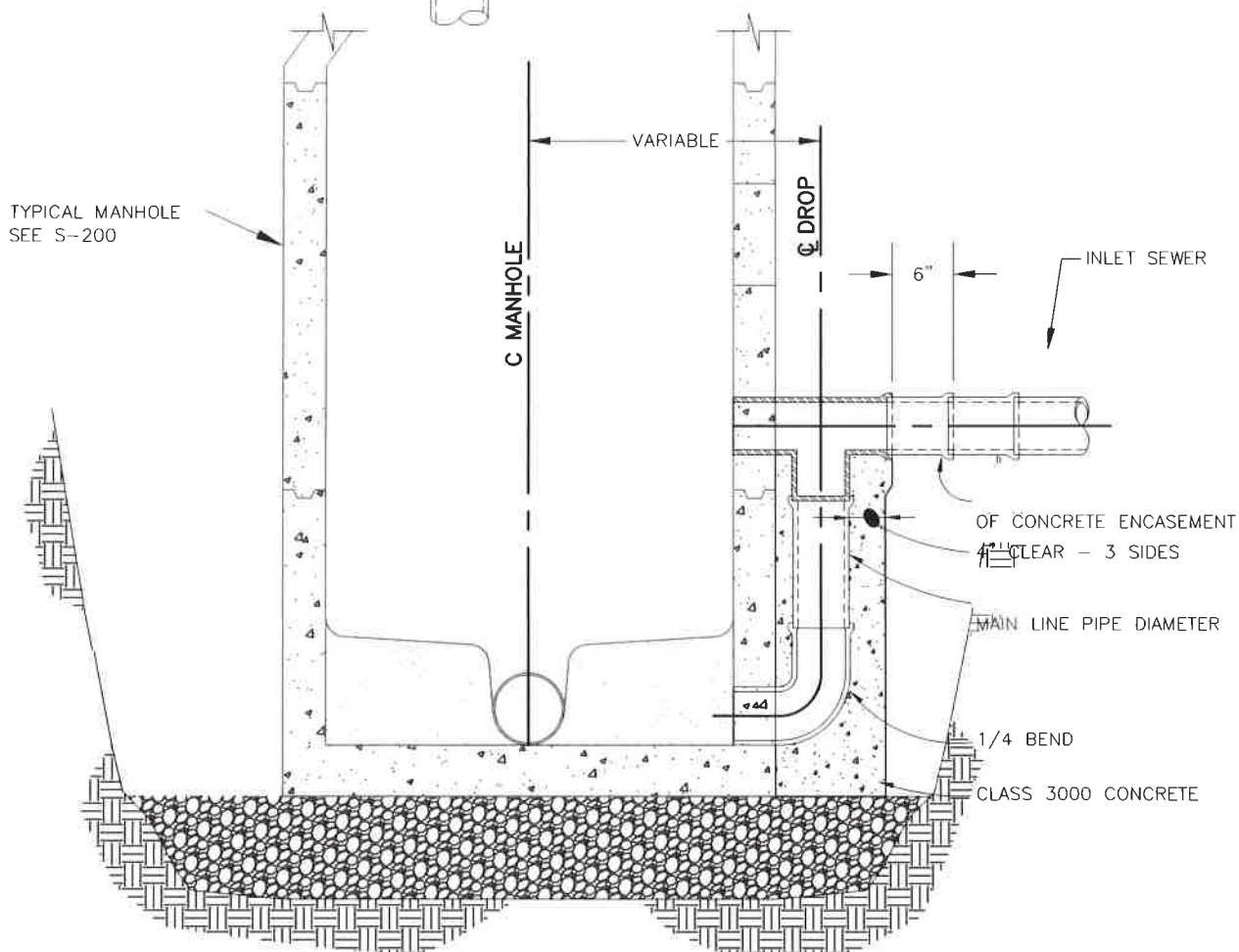

SECTION A-A

TYPICAL MANHOLE  
SEE S-200

OF CONCRETE ENCASEMENT  
4" CLEAR - 3 SIDES

MAIN LINE PIPE DIAMETER

1/4 BEND

CLASS 3000 CONCRETE



City of Cave Junction  
222 W. Lister Street  
Josephine, Oregon 97523  
(541) 592-2156

**STANDARD OUTSIDE DROP  
MANHOLE**

DETAIL NO.

**S-225**

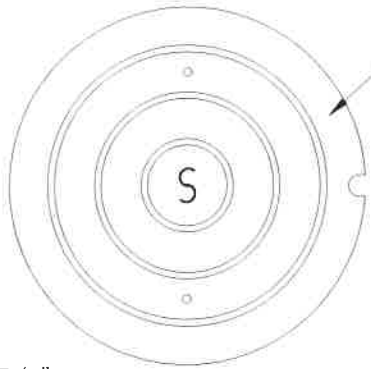

TWO HOLE 'S' COVER STANDARD  
NO VENT HOLES IN WATERTIGHT  
COVERS

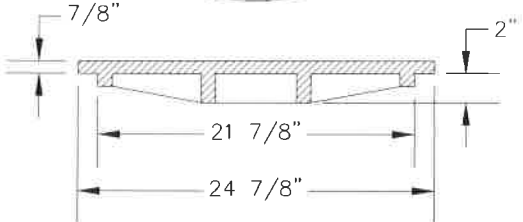

**COVER (150 LBS)**

(OLYMPIC FOUNDRY MH26S, OR APPROVED EQUAL)

WATERPROOF/BOLT-DOWN COVER  
REQUIRED IN ALL EASEMENT AND  
OFF STREET AREAS.

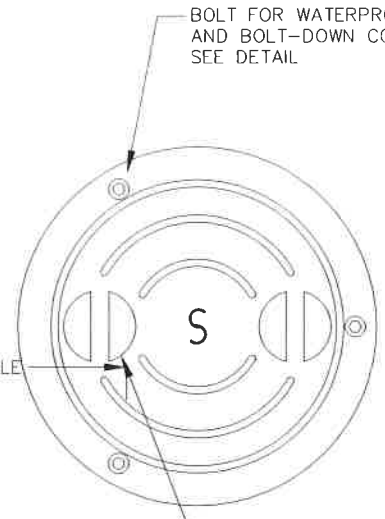

BOLT FOR WATERPROOF  
AND BOLT-DOWN COVER  
SEE DETAIL

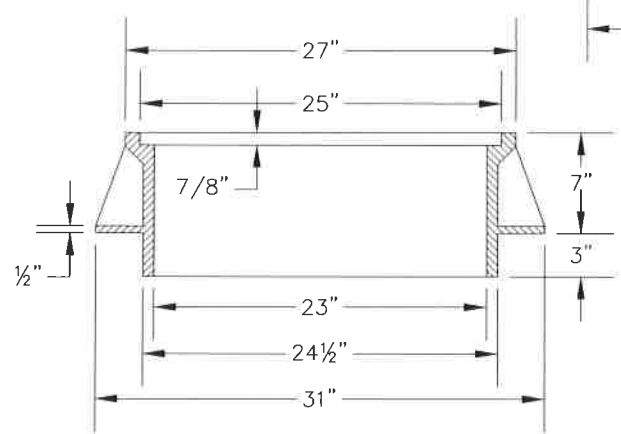

**FRAME (237 LBS)**

(OLYMPIC FOUNDRY MH26A, OR APPROVED EQUAL)

VARIABLE

DEPRESSED HANDLE

(OLYMPIC FOUNDRY MH26WT, OR APPROVED EQUAL)

NOTE:

- 1) TAMPER PROOF FRAME AND COVER REQUIRED OUTSIDE OF RIGHT OF WAY OR IN UNDEVELOPED AREAS.
- 2) MANHOLE FRAMES AND COVER SHALL HAVE H-20 RATING

1 1/4" OD STAINLESS STEEL  
WASHER, 3/32" THICK  
3 REQ'D

FLAT RUBBER WASHER  
3 REQ'D

3/8" NEOPRENE  
GASKET

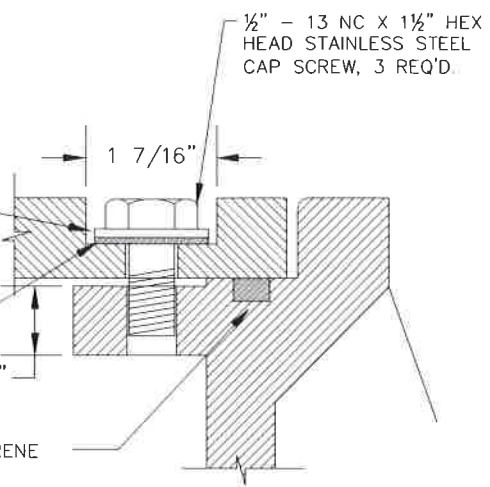

BOLT DOWN DETAIL



City of Cave Junction  
222 W. Lister Street  
Josephine, Oregon 97523  
(541) 592-2156

**MANHOLE COVER AND  
FRAME DETAILS**

DETAIL NO.  
**S-250**



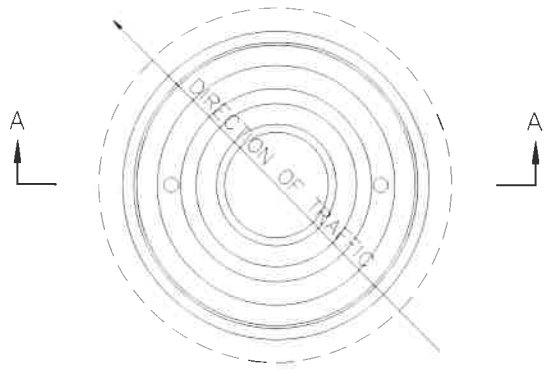

PLAN

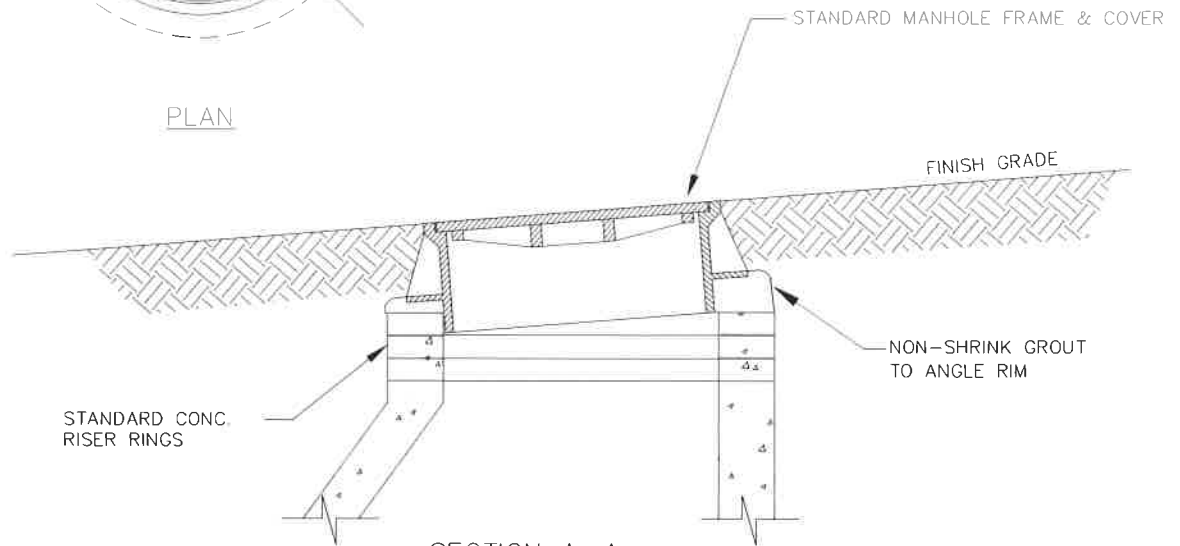

SECTION A-A

TYPICAL MANHOLE GRADE ADJUSTMENT IN STREET

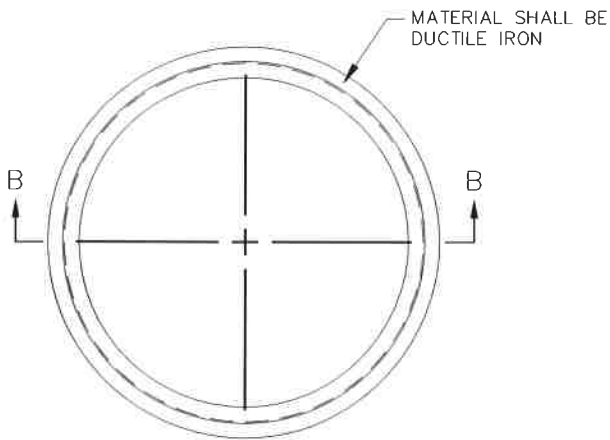

MANHOLE ADJUSTMENT RINGS  
FOR RESURFACING

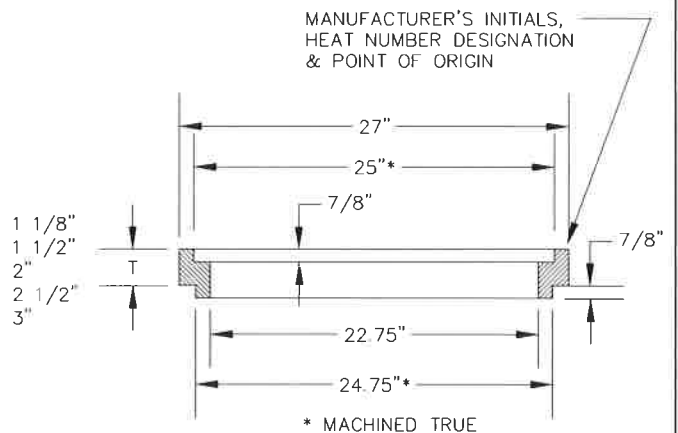

SECTION B-B



City of Cave Junction  
222 W. Lister Street  
Josephine, Oregon 97523  
(541) 592-2156

MANHOLE FRAME  
GRADE ADJUSTMENT

DETAIL NO.

S-260

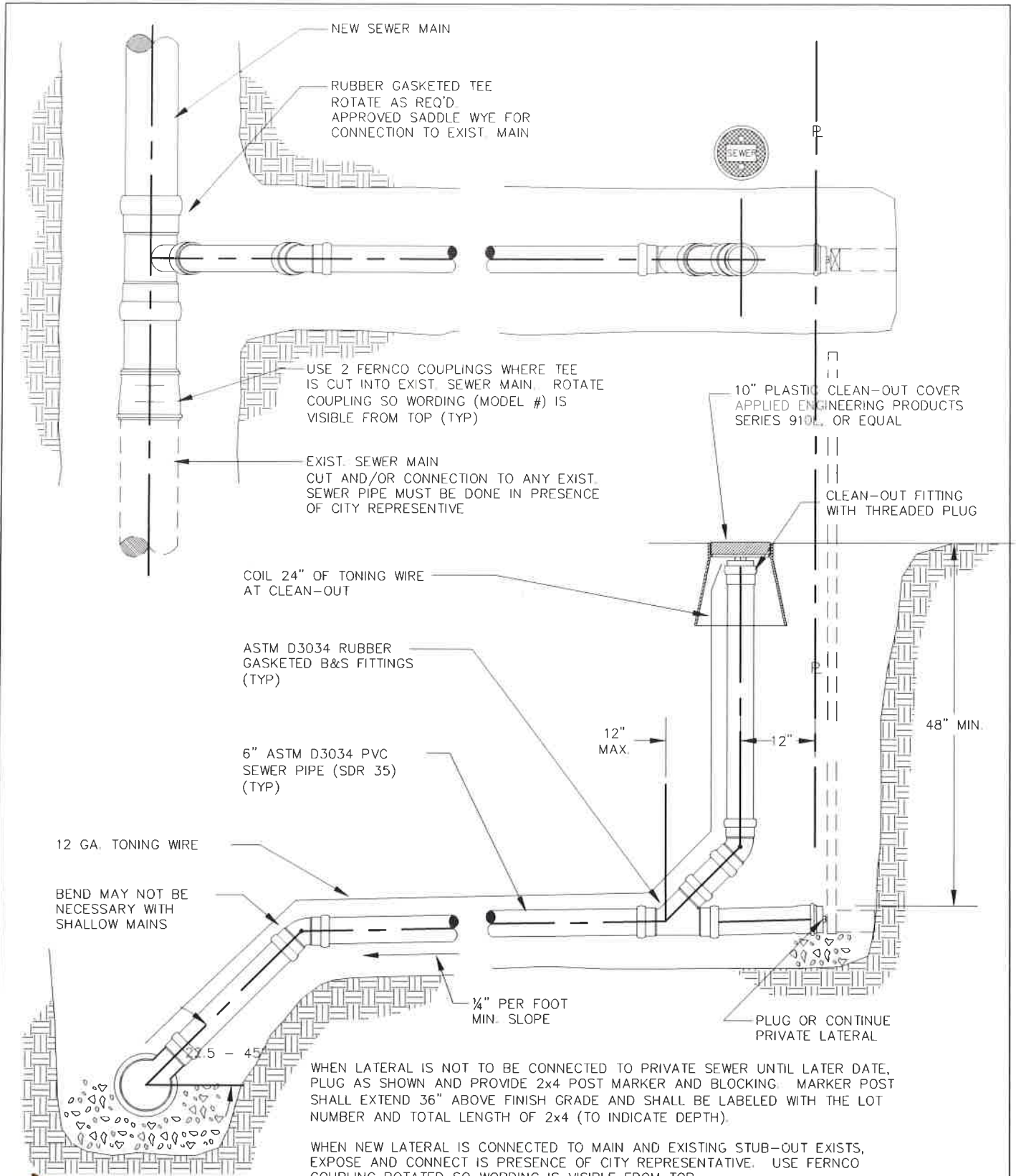

**City of Cave Junction**  
222 W. Lister Street  
Josephine, Oregon 97523  
(541) 592-2156

**STANDARD SERVICE  
CONNECTION AND LATERAL**

DETAIL NO.  
**S-300**

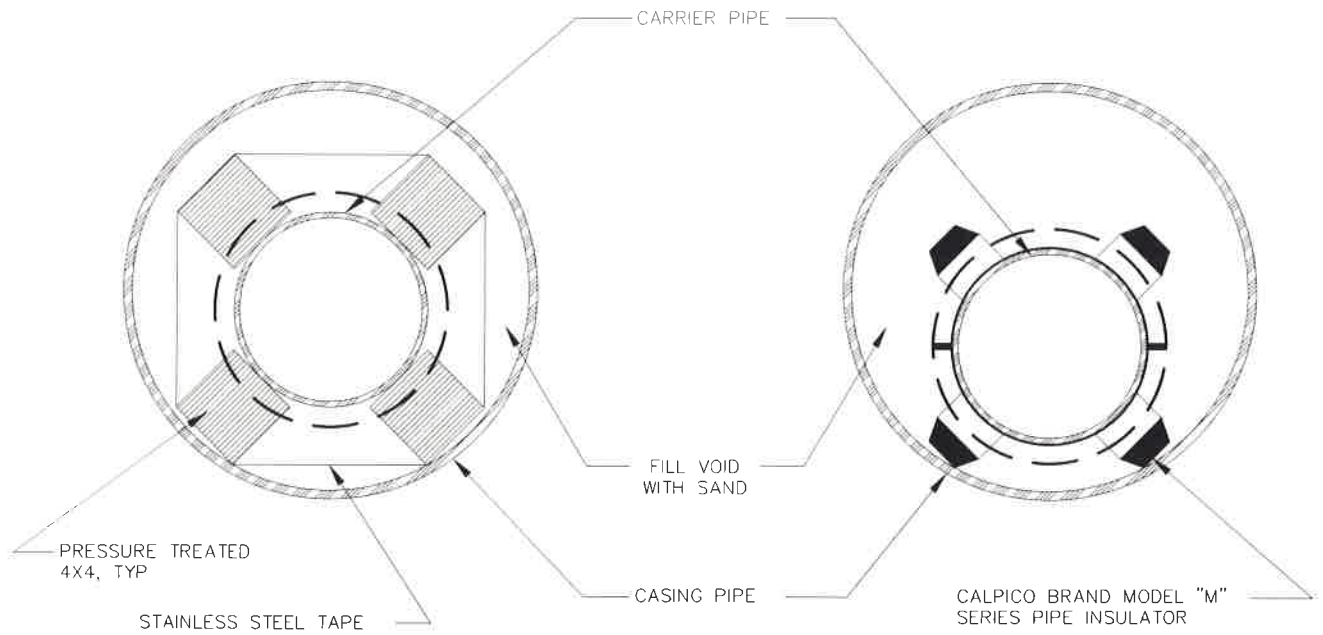

CARRIER PIPE WITH PRESSURE TREATED INSULATOR

CARRIER PIPE WITH CALPICP MODEL "M" INSULATOR

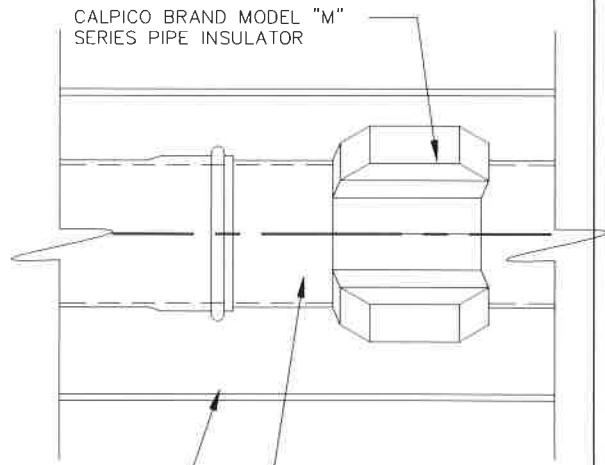
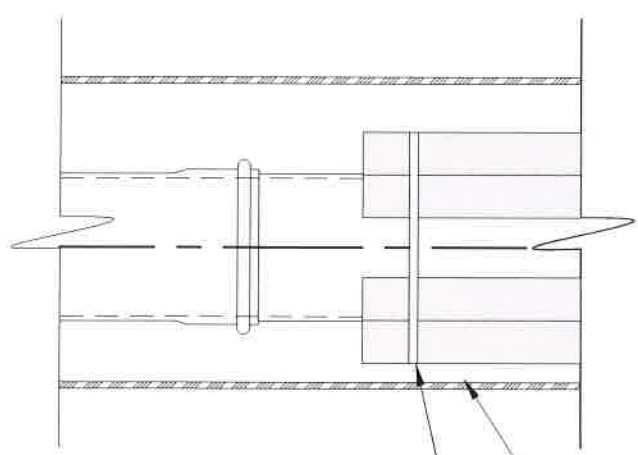

PRESSURE TREATED 4X4 TO BE 4' LONG AND STRAPPED WITH STAINLESS STEEL TAPE AT BOTH ENDS

CASING PIPE SHALL BE SMOOTH STEEL PIPE CONFORMING TO AWWA C 201 WITH MINIMUM WALL THICKNESS 3/8"

4" MIN. CLEAR SPACE BETWEEN CARRIER PIPE BELL AND CASING

PROFILE OF CARRIER PIPE WITH PRESSURE TREATED INSULATOR

PROFILE OF CARRIER PIPE WITH CALPICP MODEL "M" INSULATOR

- NOTES:
- 1) CARRIER PIPE SHALL HAVE A MINIMUM OF 2 PRESSURE TREATED INSULATORS OR 3 CALPICO MODEL "M" SERIES PER SECTION OF PIPE.
  - 2) CASING PIPE WALL THICKNESS MAY VARY DUE TO APPLICATION AND MUST BE APPROVED BY CITY ENGINEER
  - 3) SAND IS TO BE BLOWN IN TO FILL VOIDS BETWEEN CASING PIPE AND CARRIER PIPE.



**City of Cave Junction**  
 222 W. Lister Street  
 Josephine, Oregon 97523  
 (541) 592-2156

**TYPICAL PIPE CASING  
 DETAIL**

DETAIL NO.  
**S-400**